

Kingspan Insulation Limited

Pembridge
Leominster
Herefordshire HR6 9LA

Tel: 01544 388601

e-mail: info@kingspaninsulation.co.uk

website: www.kingspaninsulation.co.uk



Agrément Certificate

22/6048

Product Sheet 1 Issue 2

KINGSPAN GREENGUARD GG300 XPS INSULATION

KINGSPAN GREENGUARD GG300 XPS INVERTED ROOF INSULATION

This Agrément Certificate Product Sheet⁽¹⁾ relates to Kingspan GreenGuard GG300 XPS Inverted Roof Insulation, extruded polystyrene (XPS) boards for use in the inverted roof concept (above the roof waterproofing) on new and existing domestic and non-domestic untrafficked flat roofs, and terraces subject to pedestrian access only, with either zero fall or slopes between 1:80 and 1:6. The product is used in conjunction with the Aquazone filter/water-flow-reducing layer between the insulation and the ballast layer.

(1) Hereinafter referred to as 'Certificate'.

The assessment includes

Product factors:

- compliance with Building Regulations
- compliance with additional regulatory or non-regulatory information where applicable
- evaluation against technical specifications
- assessment criteria and technical investigations
- uses and design considerations

Process factors:

- compliance with Scheme requirements
- installation, delivery, handling and storage
- production and quality controls
- maintenance and repair

Ongoing contractual Scheme elements†:

- regular assessment of production
- formal 3-yearly review



KEY FACTORS ASSESSED

- Section 1. Mechanical resistance and stability
- Section 2. Safety in case of fire
- Section 3. Hygiene, health and the environment
- Section 4. Safety and accessibility in use
- Section 5. Protection against noise
- Section 6. Energy economy and heat retention
- Section 7. Sustainable use of natural resources
- Section 8. Durability

The BBA has awarded this Certificate to the company named above for the product described herein. This product has been assessed by the BBA as being fit for its intended use provided it is installed, used and maintained as set out in this Certificate.

On behalf of the British Board of Agrément

Date of Second issue: 29 April 2025

Originally certified on 29 March 2022

Certificate amended on 8 January 2026 to update section 1.1.2 and NHBC statement.

Hardy Giesler
Chief Executive Officer

This BBA Agrément Certificate is issued under the BBA's Inspection Body accreditation to ISO/IEC 17020. Sections marked with † are not issued under accreditation.

The BBA is a UKAS accredited Inspection Body (No. 4345), Certification Body (No. 0113) and Testing Laboratory (No. 0357).

Readers MUST check that this is the latest issue of this Agrément Certificate by either referring to the BBA website or contacting the BBA directly.

The Certificate should be read in full as it may be misleading to read clauses in isolation.

Any photographs are for illustrative purposes only, do not constitute advice and should not be relied upon.

British Board of Agrément

1st Floor, Building 3, Hatters Lane
Croxley Park, Watford
Herts WD18 8YG

©2025

tel: 01923 665300
clientservices@bbacerts.co.uk
www.bbacerts.co.uk

SUMMARY OF ASSESSMENT AND COMPLIANCE

This section provides a summary of the assessment conclusions; readers should refer to the later sections of this Certificate for information about the assessments carried out.

Compliance with Regulations

Having assessed the key factors, the opinion of the BBA is that Kingspan GreenGuard GG300 XPS Inverted Roof Insulation, if installed, used and maintained in accordance with this Certificate, can satisfy or contribute to satisfying the relevant requirements of the following Building Regulations:



The Building Regulations 2010 (England and Wales) (as amended)

Requirement:	A1	Loading
Comment:		The product can contribute to satisfying this Requirement. See section 1 of this Certificate.
Requirement:	C2(c)	Resistance to moisture
Comment:		The product can contribute to satisfying this Requirement. See section 3 of this Certificate.
Requirement:	L1(a)(i)	Conservation of fuel and power
Comment:		The product can contribute to satisfying this Requirement. See section 6 of this Certificate.
Regulation:	7(1)	Materials and workmanship
Comment:		The product is acceptable. See sections 8 and 9 of this Certificate.
Regulation:	25B	Nearly zero-energy requirements for new buildings
Regulation:	26	CO₂ emission rates for new buildings
Regulation:	26A	Fabric energy efficiency rates for new dwellings (applicable to England only)
Regulation:	26A	Primary energy rates for new buildings (applicable to Wales only)
Regulation:	26B	Fabric performance values for new dwellings (applicable to Wales only)
Regulation:	26C	Target primary energy rates for new buildings (applicable to England only)
Regulation:	26C	Energy efficiency rating (applicable to Wales only)
Comment:		The product can contribute to satisfying these Regulations. See section 6 of this Certificate.



The Building (Scotland) Regulations 2004 (as amended)

Regulation:	8(1)	Fitness and durability of materials and workmanship
Comment:		The product is acceptable. See sections 8 and 9 of this Certificate.
Regulation:	9	Building standards – construction
Standard:	1.1(b)	Structure
Comment:		The product can contribute to satisfying this Standard, with reference to clause 1.1.2 ⁽¹⁾⁽²⁾ . See section 1 of this Certificate.
Standard:	3.15	Condensation
Comment:		The product can contribute to satisfying this Standard, with reference to clauses 3.15.1 ⁽¹⁾⁽²⁾ , 3.15.3 ⁽¹⁾⁽²⁾ , 3.15.4 ⁽¹⁾⁽²⁾ , 3.15.5 ⁽¹⁾⁽²⁾ and 3.15.6 ⁽¹⁾⁽²⁾ . See section 3 of this Certificate.
Standard:	6.1(b)(c)	Energy demand
Comment:		The product can contribute to satisfying this Standard, with reference to clauses 6.1.1 ⁽¹⁾ and 6.1.2 ⁽²⁾ . See section 6 of this Certificate.

Standard: Comment:	6.2	Building insulation envelope The product can contribute to satisfying this Standard, with reference to clauses 6.2.1 ⁽¹⁾⁽²⁾ , 6.2.3 ⁽¹⁾ , 6.2.4 ⁽²⁾ , 6.2.6 ⁽¹⁾ , 6.2.7 ⁽¹⁾⁽²⁾ , 6.2.8 ⁽¹⁾⁽²⁾ , 6.2.9 ⁽¹⁾⁽²⁾ , 6.2.10 ⁽¹⁾⁽²⁾ , 6.2.11 ⁽²⁾ and 6.2.12 ⁽¹⁾ . See section 6 of this Certificate.
Standard: Comment:	7.1(a)(b)	Statement of sustainability The product can contribute to satisfying the relevant requirements of Regulation 9, Standards 1 to 6, and therefore will contribute to a construction meeting at least a bronze level of sustainability as defined in this Standard. In addition, the product can contribute to a construction meeting a higher level of sustainability as defined in this Standard, with reference to clauses 7.1.4 ⁽¹⁾ , 7.1.6 ⁽¹⁾⁽²⁾ , 7.1.7 ⁽¹⁾ , 7.1.9 ⁽²⁾ and 7.1.10 ⁽²⁾ . See section 6 of this Certificate.
Regulation: Comment:	12	Building standards – conversion All comments given for the product under Regulation 9, Standards 1 to 6, also apply to this Regulation, with reference to clause 0.12.1 ⁽¹⁾⁽²⁾ and Schedule 6 ⁽¹⁾⁽²⁾ . (1) Technical Handbook (Domestic). (2) Technical Handbook (Non-Domestic).



The Building Regulations (Northern Ireland) 2012 (as amended)

Regulation: Comment:	23(1)(a)(i) (iii)(b)(i)(ii)	Fitness of materials and workmanship The product is acceptable. See sections 8 and 9 of this Certificate.
Regulation: Comment:	29	Condensation The product can contribute to satisfying this Regulation. See section 3 of this Certificate.
Regulation: Comment:	30	Stability The product can contribute to satisfying this Regulation. See section 1 of this Certificate.
Regulation: Comment:	39(a)(i)	Conservation measures The product can contribute to satisfying this Regulation. See section 6 of this Certificate.
Regulation: Regulation: Regulation: Comment:	40(2) 43(1)(2) 43B	Target carbon dioxide emission rate Renovation of thermal elements Nearly zero-energy requirements for new buildings The product can contribute to satisfying these Regulations. See section 6 of this Certificate.

Additional Information

NHBC Standards 2025

In the opinion of the BBA, Kingspan GreenGuard GG300 XPS Inverted Roof Insulation, if installed, used and maintained in accordance with this Certificate, can satisfy or contribute to satisfying the relevant requirements in relation to *NHBC Standards*, Chapter 7.1 *Flat roofs, terraces and balconies*.

The opinion of the BBA does not amount to any endorsement or approval by NHBC and does not in any way guarantee that NHBC will approve such product / system as compliant with the NHBC Technical Requirements and Standards.

Fulfilment of Requirements

The BBA has judged Kingspan GreenGuard GG300 XPS Inverted Roof Insulation to be satisfactory for use as described in this Certificate. The product has been assessed for use as thermal insulation in the inverted roof concept (above the roof waterproofing) on new and existing domestic and non-domestic untrafficked flat roofs and terraces subject to pedestrian access only, with either zero fall or slopes between 1:80 and 1:6.

ASSESSMENT

Product description and intended use

The Certificate holder provided the following description for the product under assessment. Kingspan GreenGuard GG300 XPS Inverted Roof Insulation consists of extruded polystyrene (XPS) foam boards, rebated for lap jointing (see Figure 1).

Figure 1 Kingspan GreenGuard GG300 XPS Inverted Roof Insulation boards

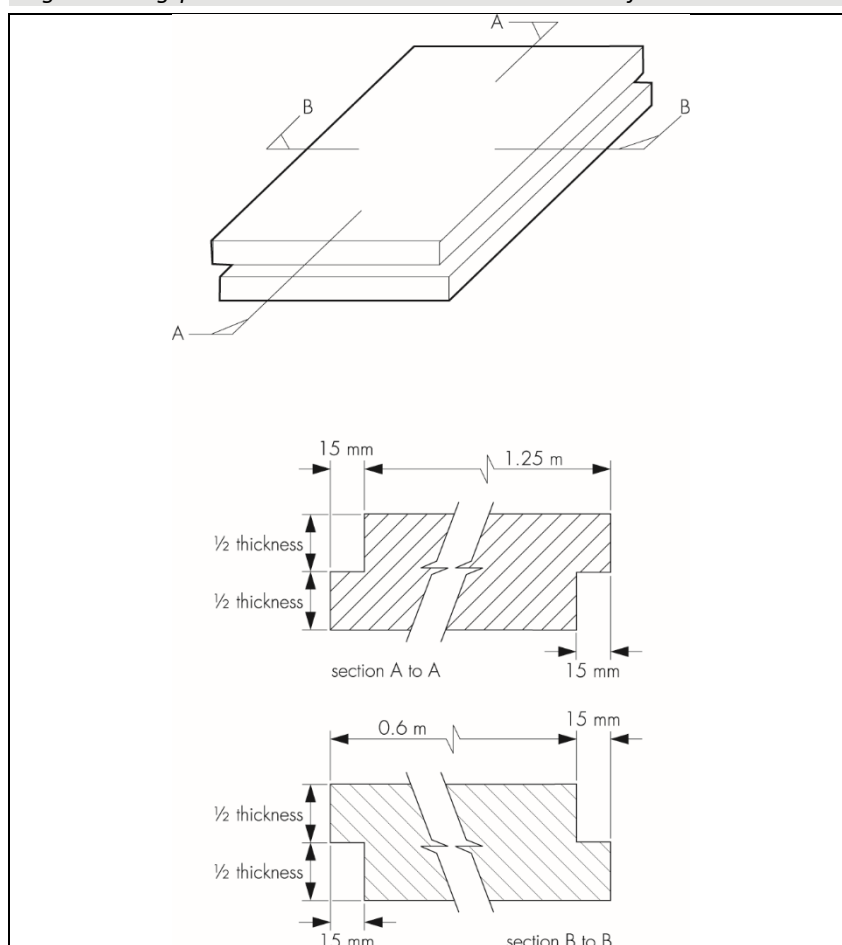

The product has the nominal characteristics given in Table 1.

Table 1 Nominal characteristics

Characteristic (unit)	Value
Work size – length x width (mm)	1250 x 600
Overall size – length and width (mm)	1265 x 615
Thickness	30, 40, 50, 60, 70, 80, 100, 120, 140, 150, 180
Edge Detail	Rebated on all 4 sides (15 mm x half board thickness)
Colour	Light green

The Aquazone filter/water-flow-reducing layer (subject of Agrément Certificate 14/5102) is used as both a filter layer and water-flow-reducing layer between the insulation and the roof ballast layer. The nominal characteristics of the Aquazone filter/water-flow-reducing layer are shown in Table 2.

Table 2 Nominal characteristics of the Aquazone filter/water-flow-reducing layer

Characteristic (unit)	Value
Material type (vapour permeable membrane)	Non-woven spun-bonded polyethylene (HDPE)
Roll size (m)	100 x 3
Membrane thickness (mm)	0.185
Mass per unit area (g·m ⁻²)	60
Lap joints (mm) — unsealed	300

Ancillary Items

The Certificate holder recommends the following ancillary items for use with the product, but these materials have not been assessed by the BBA and are outside the scope of this Certificate:

- gravel ballast laid to a minimum depth of 50 mm, or
- paving ballast of minimum 40 mm thickness
- proprietary paving support/spacer pads
- separating or cushion layers, if required
- rainwater outlet grilles
- dual-level rainwater outlets
- insulation upstand boards
- flashings and skirtings.

Applications

The product is suitable for use as thermal insulation in the inverted roof concept (above the roof waterproofing) on new and existing domestic and non-domestic untrafficked flat roofs and terraces subject to pedestrian access only, with either a zero fall or slopes between 1:80 and 1:6, on a suitably designed timber, concrete or metal structural deck and appropriate fully supported waterproofing system.

The product must always be overlaid with the Aquazone filter/water-flow-reducing layer; a gravel ballast or paving slab finish is then applied on top.

Definitions for products and applications inspected

The following terms are defined for the purpose of this Certificate as:

- flat roof — a roof having a finished fall between 1:80 and 1:6
- zero fall roof — a roof having a finished fall between 0 and 1:80
- limited access roof — a roof subjected only to pedestrian traffic for maintenance of the roof covering, cleaning of gutters, etc
- pedestrian access roof — a roof subjected to increased access to that defined for a limited access roof, but not open to vehicular traffic.

Product assessment – key factors

The product was assessed for the following key factors, and the outcome of the assessment is shown below. Conclusions relating to the Building Regulations apply to the whole of the UK unless otherwise stated.

1 Mechanical resistance and stability

Data were assessed for the following characteristics.

1.1 Strength and stability

1.1.1 The product was tested for compressive strength and the result is given in Table 3.

Table 3 Compressive stress at 10% deformation

Product assessed	Assessment method	Requirement	Result
Kingspan GreenGuard GG300 XPS Inverted Roof Insulation	BS EN 13164 : 2012	Declared value	CS(10/Y)300

1.1.2 On the basis of data assessed, the product has adequate resistance to the loads associated with light maintenance traffic on roofs, and to pedestrian foot traffic on roof terraces. The product has not been assessed for use with permanent distributed or concentrated loads, such as air conditioning units, mechanical plants, water tanks, etc. Such loads must be supported directly on the roof construction or on suitably designed support systems.

2 Safety in case of fire

Data were assessed for the following characteristics.

2.1 Reaction to fire

2.1.1 The product was tested for reaction to fire and the classification is given in Table 4.

Table 4 Reaction to fire classification

Product assessed	Assessment method	Requirement	Result ⁽¹⁾
Kingspan GreenGuard GG300 XPS Inverted Roof Insulation	BS EN 13501-1 : 2018	Declared value	F

(1) Test report no H.E-027e/20 (24 Feb 2020), issued by FIW Munchen, available from the Certificate holder on request.

2.1.2 When ballasted with a minimum 50 mm depth of aggregate, or fully supported cast stone or mineral slabs of at least 40 mm thickness, a roof will be unrestricted with regard to proximity to a relevant boundary by the documents supporting the national Building Regulations.

2.1.3 The classification and permissible areas of use of other specifications must be confirmed in accordance with the documents supporting the national Building Regulations.

2.1.4 Restrictions may apply where the product is laid over a compartment wall.

3 Hygiene, health and the environment

Data were assessed for the following characteristics.

3.1 Resistance to moisture

3.1.1 The product was tested for long term water absorption by diffusion, and additional water absorption after freeze thaw testing, and the results are given in Table 5.

Table 5 Long term water absorption by diffusion and freeze thaw

Product assessed	Assessment method	Requirement	Result
Kingspan GreenGuard GG300 XPS Inverted Roof Insulation	Long term water absorption by diffusion (% by volume) to BS EN 12088 : 2013	Value achieved	1.83
	Additional water absorption after freeze thaw (% by volume) to BS EN 12091 : 2013	Value achieved	0.74

3.1.2 The water absorption results in Table 5 are used to determine the design thermal conductivity value (λ_U) for the XPS insulation as given in Table 9.

3.2 Resistance to water and water vapour

3.2.1 The Aquazone filter/water-flow-reducing layer was tested for watertightness, water vapour resistance, and drainage factors. The results are given in Table 6.

Table 6 Watertightness, water vapour resistance⁽¹⁾, and drainage factors tests with Aquazone

Product assessed	Assessment method	Requirement	Result
Aquazone filter/water- flow-reducing layer	Watertightness to BS EN 1928 : 2000 and BS EN 13859-1 : 2010	Declared value Class W1 No leakage after 2 hours exposure to 200 mm water column	Pass
	Hydrostatic head to BS EN 20811 : 1992 and ETAG 031 : 2010	Value achieved > 1 m	Pass
	Water vapour transmission to BS EN ISO 12572 : 2016 (C)	Declared value $s_d \leq 0.025$ m	Pass
Inverted roof system Aquazone gravel ballasted/green roofs	Water flow through an inverted roof to ETAG 031 : 2010	Value achieved	0.025
Inverted roof system Aquazone with pavers on bearing pads	Water flow through an inverted roof to ETAG 031 : 2010	Value achieved	0.030

(1) Water vapour resistance, in $MN \cdot s \cdot g^{-1} \cdot m^{-1}$, may be taken as $5 \times s_d$ value.

3.3 Resistance to mechanical damage

3.3.1 Results of resistance to mechanical damage tests are given in Table 7.

Table 7 Resistance to mechanical damage tests

Product assessed	Assessment method	Requirement	Result
Aquazone filter/water-flow- reducing layer	Resistance to static loading to BS EN 12730 : 2015	Load not causing penetration	5 kg
	Tensile strength to BS EN 12311-1 : 2000	Declared value	
		Longitudinal direction Transverse direction	$\geq 280 N \cdot (50 mm)^{-1}$ $\geq 270 N \cdot (50 mm)^{-1}$
	Elongation to BS EN 12311-1 : 2000	Declared value	
		Longitudinal direction Transverse direction	$\geq 15\%$ $\geq 16\%$
	Nail tear to BS EN 12310-1 : 2000	Declared value	
		Longitudinal direction Transverse direction	$\geq 37 N$ $\geq 32 N$

3.3.2 On the basis of data assessed, the product will resist the normal loads associated with installation of the protection/ballast layer in inverted roofs.

3.3.3 The product, in conjunction with the specified protection/ballast layer, can accept the foot traffic associated with pedestrian access roofs and roof maintenance operations.

3.4 Resistance to chemicals

3.4.1 Results of resistance to chemicals are given in Table 8.

<i>Table 8 Resistance to chemicals tests</i>			
Product assessed	Assessment method	Requirement	Result
Aquazone filter/water-flow-reducing layer	Tensile strength to BS EN 13859-1 : 2010	Declared value	
	Control	$\geq 280 \text{ N} \cdot (50 \text{ mm})^{-1}$	Pass
	Longitudinal direction	$\geq 270 \text{ N} \cdot (50 \text{ mm})^{-1}$	Pass
	Transverse direction		
28 days soaking in a saturated solution of calcium hydroxide	Tensile strength to BS EN 13859-1 : 2010	No significant deterioration	
	Longitudinal direction		Pass
	Transverse direction		Pass
28 days soaking in a saturated solution of sodium chloride	Tensile strength to BS EN 13859-1 : 2010	No significant deterioration	
	Longitudinal direction		Pass
	Transverse direction		Pass
28 days soaking in a 0.5% solution of sulfuric acid	Tensile strength to BS EN 13859-1 : 2010	No significant deterioration	
	Longitudinal direction		Pass
	Transverse direction		Pass
	Elongation to BS EN 13859-1 : 2010	Declared value	
	Control	$\geq 15\%$	Pass
	Longitudinal direction	$\geq 16\%$	Pass
	Transverse direction		
28 days soaking in a saturated solution of calcium hydroxide	Elongation to BS EN 13859-1 : 2010	No significant deterioration	
	Longitudinal direction		Pass
	Transverse direction		Pass
28 days soaking in a saturated solution of sodium chloride	Elongation to BS EN 13859-1 : 2010	No significant deterioration	
	Longitudinal direction		Pass
	Transverse direction		Pass
28 days soaking in a 0.5% solution of sulfuric acid	Elongation to BS EN 13859-1 : 2010	No significant deterioration	
	Longitudinal direction		Pass
	Transverse direction		Pass

3.4.2 On the basis of data assessed, the product is resistant to the chemical conditions likely to occur in service. The product will be adversely affected by organic solvents and must be replaced if a spillage of such chemicals occurs.

4 Safety and accessibility in use

Not applicable.

5 Protection against noise

Not applicable.

6 Energy economy and heat retention

Data were assessed for the following characteristics.

6.1 Thermal conductivity

The product was tested for thermal conductivity and the result is given in Table 9.

Table 9 Thermal conductivity

Product assessed	Assessment method	Requirement	Result
Kingspan GreenGuard GG300 XPS Inverted Roof Insulation	BS EN 13164 : 2012	Design value (moisture corrected) (λ_U) ⁽¹⁾	0.035 W m ⁻¹ .K ⁻¹

(1) The design thermal conductivity value (λ_U) for the insulation is calculated using the resistance to water absorption by diffusion and freeze-thaw results given in Table 5.

6.2 Conservation of fuel and power

6.2.1 Rainfall reaching the roof waterproofing membrane will temporarily affect the rate of heat loss from the roof and should be accounted for by adding a correction (ΔU_r) to the calculated roof U value in accordance with BS EN ISO 6946 : 2017, Annex F.4, as follows (see also BBA Information Bulletin No 4):

$\Delta U_r = pf\chi (R_1/R_T)^2$ where:

- ΔU_r = correction to the calculated thermal transmittance of the roof element (W·m⁻²·K⁻¹)
- p = average rate of precipitation during the heating season (mm·day⁻¹)
- f = drainage factor giving the fraction of p reaching the waterproof membrane. See Table 6 of this Certificate
- χ = factor for increased heat loss caused by rainwater flowing on the membrane (0.04 W·day·m⁻²·K⁻¹·mm⁻¹)
- R_1 = thermal resistance of the layer of insulation above the waterproofing membrane (m²·K·W⁻¹)
- R_T = total thermal resistance of the construction before application of the correction (m²·K·W⁻¹)
- $f\cdot\chi$ = 0.001 (system incorporating the Aquazone filter/water-flow-reducing layer).

6.2.2 The U value of a completed roof will depend on the fraction of rainfall (f) penetrating the water-flow-reducing layer, the insulation thickness, type of substrate and internal finish. Example U-values are given in Table 10.

Table 10 Example U values⁽¹⁾

Required U value (W·m ⁻² ·K ⁻¹)	Kingspan GreenGuard GG300 XPS Inverted Roof Insulation, thickness required ⁽²⁾ (mm)	
	$p^{(3)} = 3$ (mm·day ⁻¹)	$p^{(3)} = 8$ (mm·day ⁻¹)
0.09	180 + 180 + 30	180 + 180 + 40
0.11	180 + 120	180 + 140
0.12	180 + 100	180 + 120
0.13	180 + 80	180 + 100
0.15	180 + 40	180 + 50
0.16	180 + 30	180 + 40
0.18	180	180 + 30
0.20	180	180

(1) Inverted roof construction — paving or gravel ballast layer; Aquazone filter/water-flow-reducing layer; Kingspan GreenGuard GG300 XPS Inverted Roof Insulation; 10 mm bitumen waterproofing layer ($\lambda = 0.23$ W·m⁻¹·K⁻¹); 200 mm reinforced concrete deck ($\lambda = 2.5$ W·m⁻¹·K⁻¹);

(2) Thinnest available insulation thickness, or thickness combination, to achieve the required U value. Thickest board as bottom layer when double/triple layer used.

(3) Values for p taken as examples of best to worst case for all UK locations, with a $f\cdot\chi$ value of 0.001 W·day·m⁻²·K⁻¹·mm⁻¹.

6.2.3 The product can contribute towards a construction satisfying the national Building Regulations in respect of energy economy and heat retention.

7 Sustainable use of natural resources

Not applicable.

8 Durability

8.1 The potential mechanisms for degradation and the known performance characteristics of the materials in the product were assessed.

8.2 Specific test data were assessed as given in Table 11.

<i>Table 11 Durability</i>			
Product assessed	Assessment method	Requirement	Result
Kingspan GreenGuard GG300 XPS Inverted Roof Insulation	Dimensional stability to BS EN 1604 : 2013 (70°C and 90% RH for 48 hours)	Length, width and reduction in thickness ≤ 5% change	Pass
	Deformation under specified compressive load and temperature conditions to BS EN 1605 : 2013 (40 kPa at 70°C for 168 hours)	≤ 5%	Pass
	Compressive strength to BS EN 826 : 2013, following freeze-thaw resistance to EN 12091 : 2013 after long-term water diffusion test to EN 12088 : 2013	Reduction in compressive stress at 10% deformation of redried specimens after freeze thaw test ≤ 10%	Pass
Aquazone filter/water- flow-reducing layer	Dimensional stability to BS EN 1107-2 : 2001	Declared value < 1%	Pass
	Flexibility at low temperature to BS EN 1109 : 2013	Declared value ≤ -40°C	Pass
	Tensile strength to BS EN 12311-1 : 2000 UV light exposure for 336 hours at 50°C followed by heat exposure for 90 days at 70°C	Declared value	
	Longitudinal direction	≥ 224 N·(50 mm) ⁻¹	Pass
	Transverse direction	≥ 216 N·(50 mm) ⁻¹	Pass
	Elongation to BS EN 12311-1 : 2000 UV light exposure for 336 hours at 50°C followed by heat exposure for 90 days at 70°C	Declared value	
	Longitudinal direction	≥ 10.5%	Pass
Transverse direction	≥ 11%	Pass	

8.3 Service life

Under normal service conditions, the product will have a life of at least 25 years, provided it is designed, installed and maintained in accordance with this Certificate and the Certificate holder's instructions.

Information provided by the Certificate holder was assessed for the following factors:

9 Design, installation, workmanship and maintenance

9.1 Design

9.1.1 The design process was assessed, and the following requirements apply in order to satisfy the performance assessed in this Certificate.

9.1.2 Concrete, metal or timber roofs must be designed in accordance with the relevant provisions of BS 6229 : 2018, BS 8217 : 2005 and BS 8218 : 1998, in particular to accommodate the weight of the ballast layer.

9.1.3 Separation or cushion layers between the insulation boards and the roof waterproofing may be needed in some circumstances (see section 9.1.9).

9.1.4 Care must be taken to ensure that upgraded roofs are capable of carrying the increased load and depth of the installed product. The structural strength and deformation of both the roof structure and the inverted roof insulation panels must be assessed by a suitably experienced and competent individual, to resist actions due to the combination of the dead load imposed by the paving and gravel ballast finish, and the imposed load from foot traffic, snow and the possible weight of rainwater (should the roof outlet[s] become blocked).

9.1.5 Decks must be covered with one or more of the following roof waterproofing specifications:

- built-up specifications using reinforced bitumen membranes to BS 8747 : 2007 installed in accordance with BS 8217 : 2005
- mastic asphalt laid in accordance with BS 8218 : 1998
- other waterproofing systems which are the subject of a current BBA Certificate, and laid in accordance with, and within the limitations imposed by, that Certificate.

9.1.6 The drainage systems must be correctly designed, and the following points must be addressed:

- provision is made for access for maintenance purposes
- drainage paths are correctly designed to avoid ponding (and the subsequent risk of silt build-up) and stresses in freezing conditions, and to reduce water entry in the event of a failure in the waterproofing layer
- for zero fall roofs, it is particularly important to identify the correct drainage points, to ensure that drainage is sufficient and effective.

9.1.7 Dual-level roof drainage must be provided to drain water off at the level of the Aquazone filter/water-flow-reducing layer, and at the level of the roof waterproofing.

9.1.8 Drainage points must be located at the lowest point of the roof, to facilitate the effective removal of rainwater. Care is needed to identify these locations. For example, precast concrete decks will deflect between spans, and mid-span may be the lowest point of the roof rather than roof edges or column supports.

9.1.9 Where there is a risk from plasticiser migration or other contaminants from the roof waterproofing (such as PVC single-ply membranes), a suitable plastic fibre or similar isolating sheet must be interposed between the roof waterproofing and the insulation boards. For loose laid single-layer roof waterproofing membranes, a cushion layer must be interposed.

9.1.10 Aquazone filter/water-flow-reducing layer must be installed above the product, with minimum 300 mm laps and covered with a gravel ballast or paving finish.

9.1.11 The ballasted roof finish may be either gravel ballast or paving, which must be assessed by a suitably experienced and competent individual according to region exposure and building height. In addition, the dead load imposed by the finish must be allowed for in calculating the total acceptable load on the deck. Care must be taken to ensure that upgraded roofs are capable of carrying the increased load and depth of the installed product. Ballast must not be stacked in one place on the roof unless the roof is capable of supporting it.

9.1.12 Gravel ballast must be washed, rounded and 16 to 32 mm in size (nominal), and laid to a minimum thickness of 50 mm. The minimum size of ballast depends on the wind loads and parapet height to prevent wind scour of the ballast. The ballast must be installed in accordance with BS EN 1991-1-4 : 2005 and its UK National Annex.

9.1.13 Paving finish ballast must comprise a minimum 40 mm thickness of cast stone, mineral or pressed concrete paving slabs. Paving slabs can be either laid fully supported, or may be supported using proprietary support/spacer pads, in accordance with the Certificate holder's recommendations.

9.1.14 Care must be taken in the overall design and construction of junctions with other elements and openings to minimise thermal bridges and air infiltration. Detailed guidance can be found in the documents supporting the national Building Regulations.

9.1.15 Roofs will adequately limit the risk of interstitial condensation when they are designed and constructed in accordance with BS 5250 : 2021. Further guidance may be obtained from BRE Report BR 262 : 2002.

9.1.16 In England and Wales, roofs will adequately limit the risk of surface condensation when the thermal transmittance (U value) does not exceed $0.35 \text{ W}\cdot\text{m}^{-2}\cdot\text{K}^{-1}$ at any point and the junctions with walls are designed in accordance with section 9.1.14 of this Certificate.

9.1.17 In Scotland, roofs will adequately limit the risk of surface condensation when the thermal transmittance (U value) does not exceed $1.2 \text{ W}\cdot\text{m}^{-2}\cdot\text{K}^{-1}$ at any point. Guidance may be obtained from BS 5250 : 2021. Further guidance may be obtained from BRE Report BR 262 : 2002 and section 9.1.14 of this Certificate.

9.2 Installation

9.2.1 Installation instructions provided by the Certificate holder were assessed and judged to be appropriate and adequate.

9.2.2 Installation must be carried out in accordance with this Certificate and the Certificate holder's instructions. A summary of instructions and guidance is provided in Annex A.

9.2.3 It is essential to establish that the roof waterproofing has been installed correctly and that it is weathertight, clean and free from any extraneous matter. Every joint between sheets, flashing and other details must be checked to ensure that the roof covering is suitable for an inverted roof specification.

9.2.4 Kingspan GreenGuard GG300 XPS Inverted Roof Insulation may be installed as a single layer, or multi-layer (double or triple layers) as required. When using multiple layers, the insulation board joints must be staggered/offset. The Certificate holder must be contacted for further advice on multi-layering, but such advice is outside the scope of this Certificate.

9.3 Workmanship

Practicability of installation was assessed by the BBA, on the basis of the Certificate holder's information. To achieve the performance described in this Certificate, installation of the product must be carried out by a competent general builder, or a contractor, experienced with this type of product.

9.4 Maintenance and repair

9.4.1 Ongoing satisfactory performance of the product in use requires that the roof is suitably maintained. The guidance provided by the Certificate holder was assessed, and found to be appropriate and adequate.

9.4.2 The following requirements apply in order to satisfy the performance assessed in this Certificate:

9.4.2.1 The product is confined and has suitable durability and so does not require maintenance.

9.4.2.2 The other components of the roofing system should be maintained in accordance with conventional good practice.

10 Manufacture

10.1 The production processes for the product have been assessed, and provide assurance that the quality controls are satisfactory according to the following factors:

10.1.1 The manufacturer has provided documented information on the materials, processes, testing and control factors.

10.1.2 The quality control operated over batches of incoming materials has been assessed and deemed appropriate and adequate.

10.1.3 The quality control procedures and product testing to be undertaken have been assessed and deemed appropriate and adequate.

10.1.4 The process for management of non-conformities has been assessed and deemed appropriate and adequate.

10.1.5 An audit of each production location was undertaken, and it was confirmed that the production process was in accordance with the documented process, and that equipment has been properly tested and calibrated.

†10.2 The BBA has undertaken to review the above measures on a regular basis through a surveillance process, to verify that the specifications and quality control operated by the manufacturer are being maintained.

11 Delivery and site handling

11.1 The Certificate holder stated that the product is delivered to site in polythene shrink-wrapped packs incorporating a label with the Certificate holder's name, product description and characteristics, and the BBA logo incorporating the number of this Certificate.

11.2 Delivery and site handling must be performed in accordance with the Certificate holder's instructions and this Certificate, including:

11.2.1 The product must be stored flat, off the ground on a clean, level surface, and under cover or protected with opaque polythene, to protect it from high winds and prolonged exposure to sunlight. Where possible, packs should be stored inside. If outside, the boards must be raised above ground level.

11.2.2 Care must be exercised to avoid crushing the edges or corners. If damaged, the product must be discarded.

11.2.3 The product must not be exposed to open flame or other ignition sources, or to solvents or other chemicals.

Supporting information in this Annex is relevant to the product but has not formed part of the material assessed for the Certificate.

Construction (Design and Management) Regulations 2015

Construction (Design and Management) Regulations (Northern Ireland) 2016

Information in this Certificate may assist the client, designer (including Principal Designer) and contractor (including Principal Contractor) to address their obligations under these Regulations.

UKCA marking

The Certificate holder has taken the responsibility of UKCA marking the product in accordance with Designated Standard EN 13164 : 2012.

CE marking

The Certificate holder has taken the responsibility of CE marking the product in accordance with harmonised European Standard EN 13164 : 2012.

Management Systems Certification for production

The management system of the manufacturer has been assessed and registered as meeting the requirements of BS EN ISO 9001 : 2015 and BS EN ISO 14001 : 2015 by CIBSE Certification Ltd (Certificates 0001QMS-1 and 0001EMS-1 respectively).

Additional Guidance

A.1 Additional guidance for inverted roof specifications is given in BBA Information Bulletin No. 4 *Inverted roofs – Drainage and U value corrections*.

A.2 Reference should be made to the appropriate clauses of the LRWA Guidance Note No. 7 : 2012 *Specifier Guidance for Flat Roof Falls*, which generally requires surface drainage falls in most situations.

Additional information on installation

Installation must be in accordance with the Certificate holder's instructions and this Certificate.

A.3 The product can be cut using a fine-toothed saw, sharp knife or a hot wire cutter.

A.4 Kingspan GreenGuard GG300 XPS Inverted Roof Insulation is laid in a brick-bond pattern; it is essential that all joints between the boards are tight and that no gaps exist where they meet rooflights, edge details and other services which perforate the roof deck.

A.5 When the product is to be placed over a loose-laid roof covering, it must be installed and ballasted as soon as possible to protect the covering from the effects of wind uplift (see sections 9.1.10 to 9.1.13) and installers must take care not to damage the existing roof waterproofing.

A.6 Kingspan GreenGuard GG300 XPS Inverted Roof Insulation may be installed in any weather but, due to its size, care is required in high winds. Installers must not carry it near to parapets or apertures in the deck and once placed, the product must be covered with the Aquazone filter/water-flow-reducing layer and ballasted as soon as possible.

A.7 The ballast loading layer must be installed in accordance with BS 6399-2 : 1997, BS EN 1991-1-4 : 2005, BRE Digest 295 : 1985 and BRE Digest 311 : 1986.

A.8 The ballast loading layer must be applied as work progresses to protect the insulation and the filter/water-control layer from the effects of wind uplift, solar degradation and foot traffic.

Upgrading roofs

A.9 In existing roofs, the requirements of sections A.3 to A.8 also apply. In addition, the existing roofing and substructure must be examined for degradation and, where necessary, repairs effected. Particular consideration should be given to the condensation risk that the existing roof structure may present.

A.10 Where, for example, parapets, details and services have insufficient height to accommodate the increased depth of insulation/protection, a minimum of 150 mm from the top of the gravel to the top of the skirtings must be provided.

A.11 If upgrading involves laying the product on existing inverted roof insulation, the advice of the Certificate holder should be sought, but such advice is outside the scope of this Certificate.

A.12 Rainwater outlets may need to be modified or replaced to suit, eg by the installation of gravel guards.

Procedure

A.13 Single-layer roofing must be the subject of very close scrutiny, and the inspection must include an examination for perforation and for the likelihood of subsequent perforation from beneath (by, for example, uneven decks and protruding nail heads).

A.14 The Aquazone filter/water-flow-reducing layer should be loose-laid over the insulation, at right angles to the slope, with 300 mm unsealed lap joints overlapping in the downward direction of the flat roof slope. At upstands and penetrations, the Aquazone filter/water-flow-reducing layer must be turned up to finish level with the top surface of the ballast layer (either gravel ballast or paving slabs) and turned down into drainage outlets.

A.15 The ballast layer (comprising either a gravel ballast or paving slabs) must then be laid over the Aquazone filter/water-flow-reducing layer as soon as possible, to prevent flotation, wind uplift, UV degradation and damage from foot traffic.

Gravel ballast finish

A.16 The gravel ballast layer must be carefully placed directly over the Aquazone filter/water-flow-reducing layer to ensure complete depth and cover is achieved over the entire surface of the product.

A.17 Gravel must not contain excessive fines in order to prevent clogging of gullies and outlets and to discourage organic growth.

Paving slab finish

A.18 Standard pressed concrete, cast stone or mineral paving slabs of at least 40 mm thickness (see sections 2.1.2 and 9.1.13) must be carefully placed directly over the Aquazone filter/water-flow-reducing layer to ensure complete cover is achieved over the entire surface of the product. Paving slabs can either be laid fully supported, or may be supported using proprietary support/spacer pads.

A.19 Typical construction details are given in Figures 2 to 4.

Figure 2 Typical installation/parapet detail — gravel ballast finish

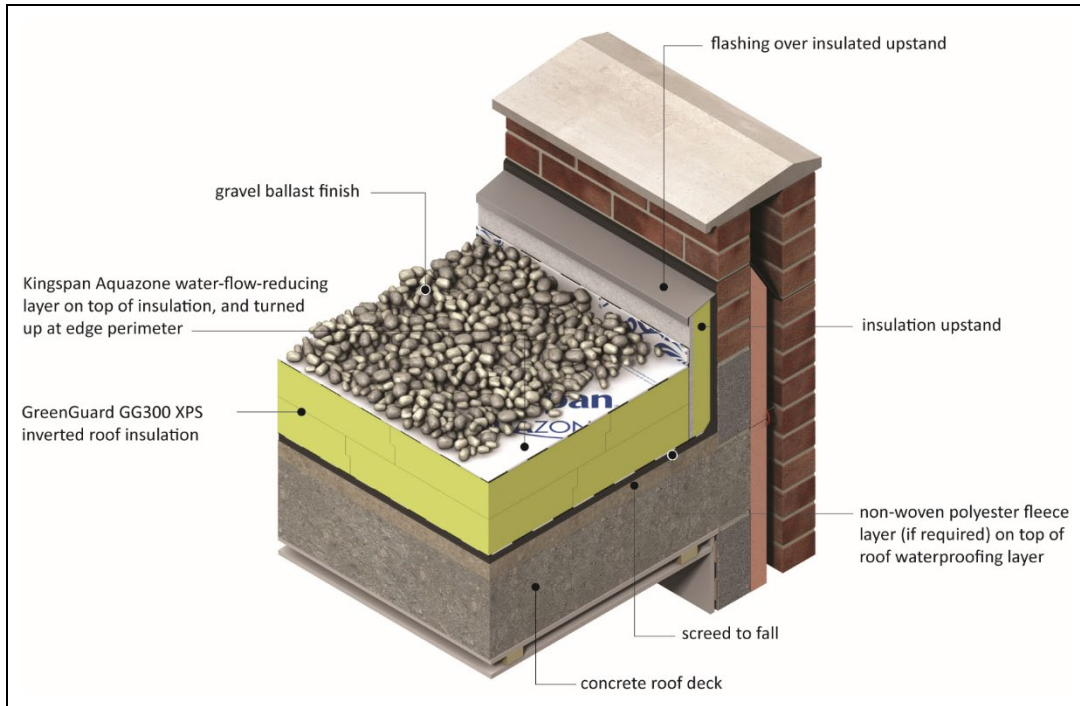

Figure 3 Parapet detail — paving finish

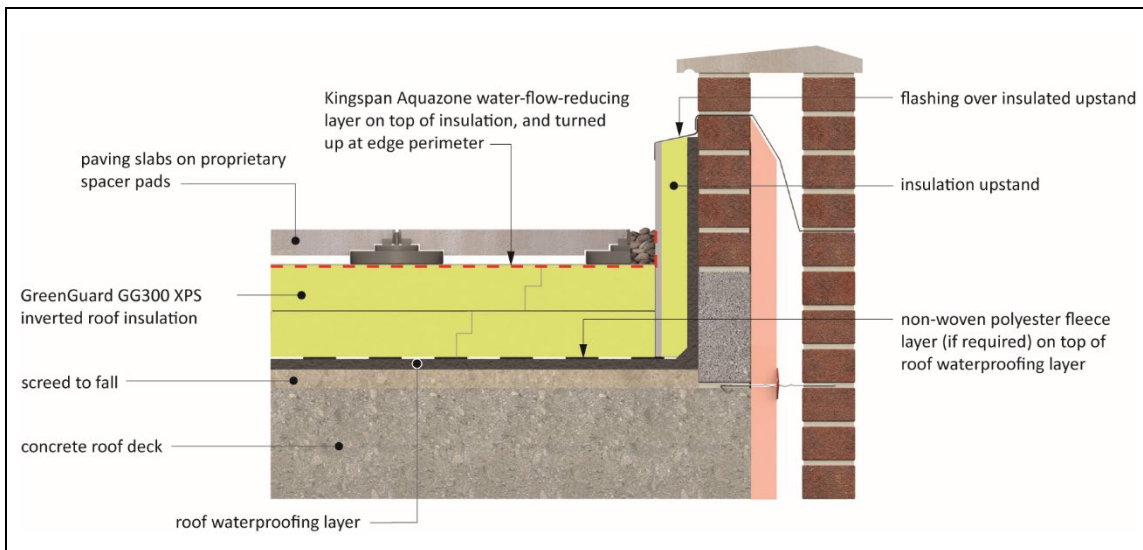
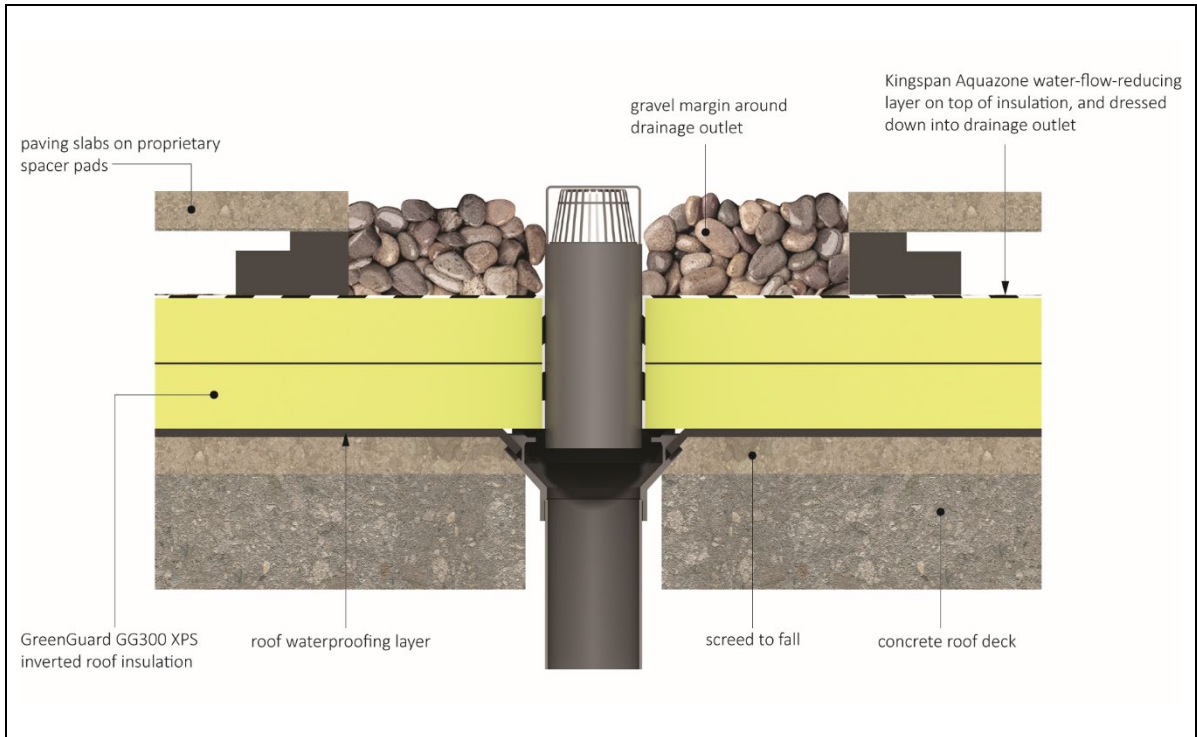

Figure 4 Water outlet detail — paving finish



Bibliography

BBA Information Bulletin No. 4 – *Inverted roofs – Drainage and U value corrections*

BRE Digest 295 : 1985 *Stability under wind load of loose-laid external roof insulation boards*

BRE Digest 311 : 1986 *Flat roof design: the technical options*

BRE Report BR 262 : 2002 *Thermal insulation: avoiding risks*

BS 5250 : 2021 *Management of moisture in buildings — Code of practice*

BS 6229 : 2018 *Flat roofs with continuously supported coverings — Code of practice*

BS 6399-2 : 1997 *Loading for buildings – Code of practice for wind loads*

BS 8217 : 2005 *Reinforced bitumen membranes for roofing — Code of practice*

BS 8218 : 1998 *Code of practice for mastic asphalt roofing*

BS 8747 : 2007 *Reinforced bitumen membranes (RBMs) for roofing — Guide to selection and specification*

BS EN 1107-2 : 2001 *Flexible sheets for waterproofing — Determination of dimensional stability — Plastic and rubber sheets for roof waterproofing*

BS EN 1109 : 2013 *Flexible sheets for waterproofing — Bitumen sheets for roof waterproofing — Determination of flexibility at low temperature*

BS EN 1604 : 2013 *Thermal insulating products for building applications — Determination of dimensional stability under specified temperature and humidity conditions*

BS EN 1605 : 2013 *Thermal insulating products for building applications — Determination of deformation under specified compressive load and temperature conditions.*

BS EN 1928 : 2000 *Flexible sheets for waterproofing – Bitumen, plastic and rubber sheets for roof waterproofing- Determination of watertightness*

BS EN 1991-1-4 : 2005 + A1 : 2010 *Eurocode 1 — Actions on structures — General actions — Wind actions*
NA to BS EN 1991-1-4 : 2005 + A1 : 2010 *UK National Annex to Eurocode 1 : Actions on structures — General actions — Wind actions*

BS EN 826 : 2013 *Thermal insulating products for building applications — Determination of compression behaviour*

BS EN 12088 : 2013 *Thermal insulating products for building applications — Determination of long term water absorption by diffusion*

BS EN 12091 : 2013 *Thermal insulating products for building applications— Determination of freeze thaw resistance*

BS EN 12310-1 : 2000 *Flexible sheets for waterproofing — Determination of resistance to tearing (nail shank) — Bitumen sheets for roof waterproofing*

BS EN 12311-1 : 2000 *Flexible sheets for waterproofing — Determination of tensile properties — Bitumen sheets for roof waterproofing*

BS EN 12730 : 2015 *Flexible sheets for waterproofing — Bitumen, plastic and rubber sheets for roof waterproofing — Determination of resistance to static loading*

BS EN 13164 : 2012 + A1 : 2015 *Thermal insulation products for buildings — Factory made extruded polystyrene (XPS) products — Specification*

BS EN 13501-1 : 2018 *Fire classification of construction products and building elements — Classification using test data from reaction to fire test*

BS EN 13859-1 : 2010 *Flexible sheets for waterproofing – Definitions and characteristics of underlays – Underlays for discontinuous roofing*

BS EN 20811 : 1992 *Textiles – Determination of resistance to water penetration – Hydrostatic pressure test*

BS EN ISO 6946 : 2017 *Building components and building elements — Thermal resistance and thermal transmittance — Calculation method*

BS EN ISO 9001 : 2015 *Quality management systems — Requirements*

BS EN ISO 14001 : 2015 *Environmental management systems — Requirements with guidance for use*

BS EN ISO 12572 : 2016 *Hygrothermal performance of building materials and products — Determination of water vapour transmission properties — Cup method*

ETAG 031 : 2010 *Guideline for the European Technical Approval of Inverted Roof Insulation Kits*

LRWA Guidance Note No. 7 : 2012 *Specifier Guidance for Flat Roof Falls*

Conditions of Certificate

Conditions

1 This Certificate:

- relates only to the product that is named and described on the front page
- is issued only to the company, firm, organisation or person named on the front page – no other company, firm, organisation or person may hold or claim that this Certificate has been issued to them
- has to be read, considered and used as a whole document – it may be misleading and will be incomplete to be selective
- is copyright of the BBA
- and any matter arising out of or in connection with it or its subject matter (including non-contractual disputes or claims) is governed by and construed in accordance with the law of England and Wales.
- the courts of England and Wales shall have exclusive jurisdiction to settle any matter arising out of or in connection with this Certificate or its subject matter (including non-contractual disputes or claims).

2 Publications, documents, specifications, legislation, regulations, standards and the like referenced in this Certificate are those that were current and/or deemed relevant by the BBA at the date of issue or reissue of this Certificate.

3 This Certificate will be displayed on the BBA website, and the Certificate Holder is entitled to use the Certificate and Certificate logo, provided that the product and its manufacture and/or fabrication, including all related and relevant parts and processes thereof:

- are maintained at or above the levels which have been assessed and found to be satisfactory by the BBA
- continue to be checked as and when deemed appropriate by the BBA under arrangements that it will determine
- are reviewed by the BBA as and when it considers appropriate.

4 The BBA has used due skill, care and diligence in preparing this Certificate, but no warranty is provided.

5 In issuing this Certificate the BBA is not responsible and is excluded from any liability to any company, firm, organisation or person, for any matters arising directly or indirectly from:

- the presence or absence of any patent, intellectual property or similar rights subsisting in the product or any other product
- the right of the Certificate holder to manufacture, supply, install, maintain or market the product
- actual installations of the product, including their nature, design, methods, performance, workmanship and maintenance
- any works and constructions in which the product is installed, including their nature, design, methods, performance, workmanship and maintenance
- any loss or damage, including personal injury, howsoever caused by the product, including its manufacture, supply, installation, use, maintenance and removal
- any claims by the manufacturer relating to UKCA marking and CE marking.

6 Any information relating to the manufacture, supply, installation, use, maintenance and removal of this product which is contained or referred to in this Certificate is the minimum required to be met when the product is manufactured, supplied, installed, used, maintained and removed. It does not purport in any way to restate the requirements of the Health and Safety at Work etc. Act 1974, or of any other statutory, common law or other duty which may exist at the date of issue or reissue of this Certificate; nor is conformity with such information to be taken as satisfying the requirements of the 1974 Act or of any statutory, common law or other duty of care.

British Board of Agrément

1st Floor, Building 3, Hatters Lane
Croxley Park, Watford
Herts WD18 8YG

©2025

tel: 01923 665300
clientservices@bbacerts.co.uk
www.bbacerts.co.uk