

Kooltherm® K108 Cavity Board

Indicative Ψ -values (psi-values) for 100 mm insulation board in a 150 mm cavity

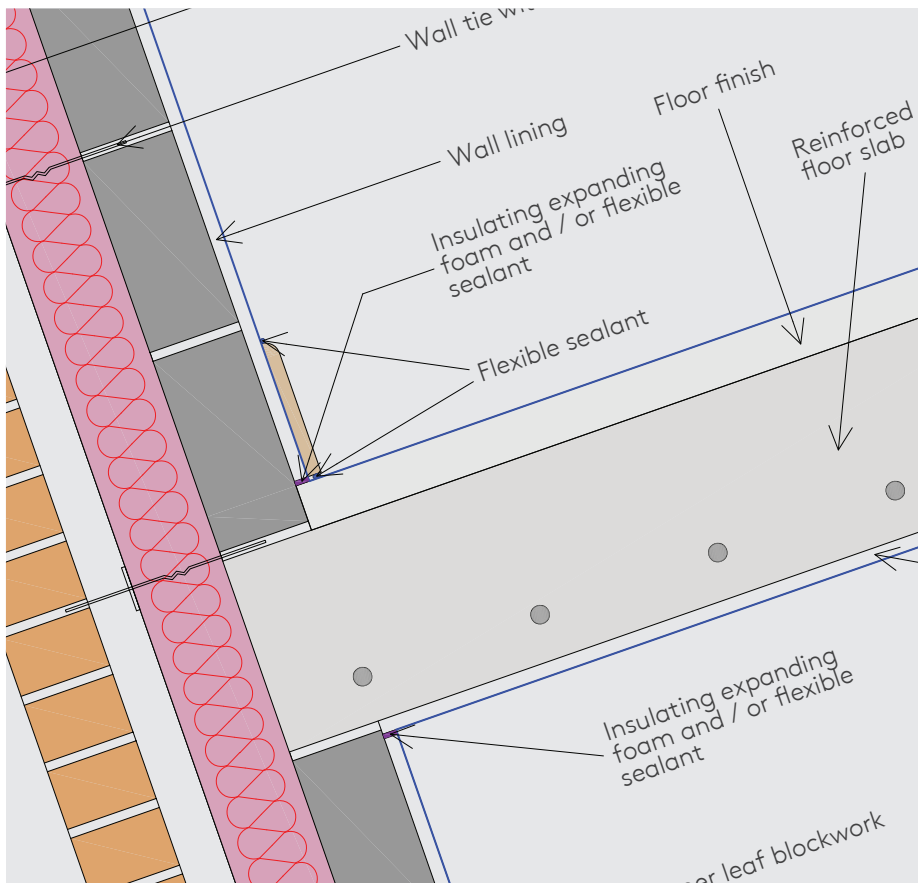

- Indicative Ψ -values for the majority of the most common junction types
- Temperature factors provided for each junction
- Achieved U-value results for the elements in each junction
- Ψ -values covering a variety of blockwork thermal conductivities
- Illustrative and temperature diagrams provided for each junction type
- Summary sheet of results for ease of reference
- SAP evidence sheet for energy assessors
- List of material properties used in the modelling

Contents

Introduction & how to use this book		Pages
	Heat loss from junctions	3
	Junctions & building compliance	3
	Thermal modelling of junctions	3
	Critical temperature factors	4
	How to use these details	4
	Calculation methodology	4
	Limitations & applicability of modelling	4
<hr/>		
External wall details		
E1	Open back lintel (insulated) with perforated steel base plate	5 - 6
	Open back lintel (insulated) with perforated steel base plate - insulated reveal	7 - 8
E3	Window sills – un-insulated reveal	9 - 10
	Window sills – insulated reveal	11 - 12
E4	Window jambs – un-insulated reveal	13 - 14
	Window jambs – insulated reveal	15 - 16
E5	Ground floor – solid concrete slab	17 - 18
	Ground floor – beam and block (perpendicular)	19 - 20
	Ground floor – beam and block (parallel)	21 - 22
	Ground floor – suspended timber floor	23 - 24
E6	Intermediate floor (concrete)	25 - 26
	Intermediate floor (timber)	27 - 28
E10	Eaves (insulation at ceiling level)	29 - 30
E11	Eaves (insulation at rafter level)	31 - 32
E12	Gable (insulation at ceiling level)	33 - 34
E13	Gable (insulation at rafter level)	35 - 36
E14	Flat roof	37 - 38
E15	Flat roof with parapet	39 - 40
E16	Corner	41 - 42
E17	Inverted corner	43 - 44
E18	Party wall between dwellings - filled cavity	45 - 46
	Party wall between dwellings - un-filled cavity	47 - 48
<hr/>		
Additional information		
	Appendix A: summary of linear thermal transmittance Ψ (W/mK) results	49
	Appendix B: SAP evidence sheets	50
	Appendix C: list of material properties	51

Introduction

Heat loss from junctions

Thermal bridging occurring at the junctions of a building's planar elements (i.e. between roofs, walls, openings, and floors) can add significantly to a building's total fabric heat loss.

Higher heat flows occur at junctions due to complex geometries, or from the use of materials with a higher thermal conductivity than the adjacent materials. This can cause localised reductions in the internal surface temperatures, which can lead to surface condensation and mould growth problems. Good design detailing can help to avoid these issues. The details in this guidance have been developed with the aims of being buildable, achieving good thermal performance and minimal risk.

Linear thermal bridging describes the heat-loss occurring at junctions between elements e.g. between a wall and floor, or around openings e.g. at sills, lintels and jambs.

A Ψ -value (psi-value) is the heat loss through a junction, which is additional to the heat flow through the adjoining plane elements, and is expressed in W/mK.

Ψ -values are not taken into account in U-value calculations, but, instead, they are taken into account separately in the calculation methodologies e.g. the Standard Assessment Procedure (SAP) that are used to assess the operational CO₂ emissions and, where applicable, the fabric energy efficiency of buildings, primary energy or delivered energy rates.

Junctions & building compliance

There are four possibilities for specifying thermal bridging:

- a. details conform to those of a reputable non-government database containing independently assessed thermal junction details, such as Local Authority Building Control's Construction Details library.
- b. Ψ -values calculated by a person with suitable expertise and experience in accordance with RE IP 1/06 (Assessing the effects of thermal bridging at junctions and around openings) and BR 497: 2016 (Conventions for calculating linear thermal transmittance and temperature factors). In this case, use those calculated Ψ -values along with the length of each junction.

- c. use the individual junction default values in the Standard Assessment Procedure, Table K1.
- d. use a global default value for overall heat losses in the energy calculation to take account of the heat loss due to thermal bridging (a value of 0.20 W/m²K is added to overall elemental losses, making it harder to achieve compliance).

A combination of details can be used and where some details are missing, the Ψ -values from the 'default' column in Table K1 can be used.

The Ψ -values in this document have all been calculated by persons with suitable expertise and experience as per the second of the above options.

Where options (a) or (b), or a combination of them, are used appropriate consideration should be given to on-site audits, inspection and associated documentation to meet the evidentiary requirements necessary to claim the associated Ψ -value in the energy assessment.

Please note that there are potential restrictions placed upon this product which vary dependant on building type, height, construction and location in Great Britain. For guidance regarding the routes to compliance for meeting the fire safety requirements of the Building Regulations / Standards in Great Britain, refer to the relevant Technical Bulletins and links to Government websites at www.kingspaninsulation.co.uk/fireregulations

Thermal modelling of junctions

Ψ -values have been created for the major junctions involving Kingspan Kooltherm® K108 Cavity Board following the guidelines in BR 497: 2016.

All thermal modelling work was undertaken by competent thermal modellers Thermal Modellers (who have successfully completed training and portfolios to become members of the Elmhurst Psi-Value Competency Scheme and are experienced in thermal modelling of junction heat losses) on behalf of Kingspan Insulation Ltd.

All of the calculated Ψ -values for the junction details are better than the default Ψ -values given in Table K1 of SAP 10.

Kingspan Insulation thermal modelling

Critical temperature factors

Reasonable provision to avoid surface condensation, or mould growth occurring as a result of thermal bridges, is to demonstrate that the details achieve a temperature factor that is no worse than the performance set out in BRE IP 1/06.

The temperature factor is a property of the construction, surface resistance and internal and external temperatures. It is used to assess the risk of surface condensation or mould growth. This parameter has been provided for all of the junction variants.

In all cases the calculated values are higher than the critical temperature factor for dwellings (f_{CRsi} of 0.75) as given in BRE IP 1/06, which limits the risk of surface condensation or mould growth. Higher humidity condition buildings for example swimming pools (f_{CRsi} of 0.90), may require alternative details and constructions.

All of the modelled Kingspan Kooltherm® K108 details achieve acceptable temperature factors.

Calculation methodology

The thermal modelling of Kingspan Kooltherm® K108 details was undertaken using Physibel's TRISCO and Blocon's HEAT2 and HEAT3. All are steady state thermal modelling software which have validated against BS EN ISO 10211: 2017 (Thermal bridges in building construction. Heat flows and surface temperatures. Detailed calculations).

The modelled U-values and underfloor temperatures for suspended and beam and block floors were determined in accordance with Annex G of BS EN ISO 13370: 2017 (Thermal performance of buildings. Heat transfer via the ground. Calculation methods).

Junctions were modelled using Kingspan Kooltherm® K108 100 mm insulation in a 150 mm masonry cavity, with a 12.5 mm plasterboard on plaster dabs, and a blockwork inner leaf of varying thermal conductivities. The thermal conductivity of the low conductivity blockworks was adjusted as per 3.1.3.3 of BR 497. More detailed build ups for wall and roof constructions are detailed within the individual pages of this document. For Kingspan Kooltherm® K108 product information please refer to the **product literature**.

How to use these details

The detail sheets include a process sequence and also guidance on how to achieve a good level of air-tightness.

The Ψ -values and temperature factors are provided for different thermal conductivities of inner leaf blockwork. Where a different blockwork thermal conductivity is used, performance can be inferred from the poorer closest blockwork thermal conductivity.

The Ψ -values cited may be used in calculations of building heat loss, where the principles of construction and key element specifications have been followed.

Limitations & applicability of modelling

Calculated Ψ -values can be used by energy assessors for buildings constructed in accordance with associated details for England, Scotland, Wales and Northern Ireland.

Where proposed constructions significantly differ from the enclosed process sequences, or use alternative materials, these Ψ -values and temperature factors should not be used. In addition where the product differs or is substituted, these details should not be used.

These details represent typical detailing to achieve a good level of thermal performance, however the details included in this document may not be suitable for use in all circumstances. Where there is any uncertainty, Building Control Body (BCB) requirements and advice should always be sought and followed. All other site requirements and relevant building regulations must be taken into consideration when implementing the details.

The details and thermal models contained within this document are indicative only, designed to provide a basis for Ψ -value calculations and thermal junction performance. The actual design and requirements of each project regarding (but not limited to), acoustics, fire, structure, moisture, etc. will need to be determined and checked by the designer, fire engineer and other relevant parties on the project. Although every effort has been made to provide accurate information, Kingspan Insulation can accept no liability for any issues arising from its use.

E1 – Open back lintel (insulated) with perforated steel base plate

General construction specification

- Wall (12.5 mm plasterboard on dabs)
- Inner leaf blockwork
- 150 mm overall cavity width with 100 mm Kingspan Kooltherm® K108 Cavity Board and 50 mm cavity
- Outer leaf brickwork

Air barrier process sequence

- Apply flexible sealant to all interfaces between the internal air barrier and the window / door frame.
- Seal all penetrations through the air barrier using a flexible sealant.
- Seal the joint between the window frame and the internal linings.

Thermal performance process sequence

- Ensure Kingspan Kooltherm® K108 is in contact with the lintel.
- Ensure there are no gaps between the insulation boards.
- For normal reveals, ensure the window / door frame overlaps the lintel by no less than 30 mm.
- Kingspan Kooltherm® K108 should be firmly held against the inner leaf of blockwork.
- The cavity and wall ties should be kept clean of mortar and other debris during construction.

Detail

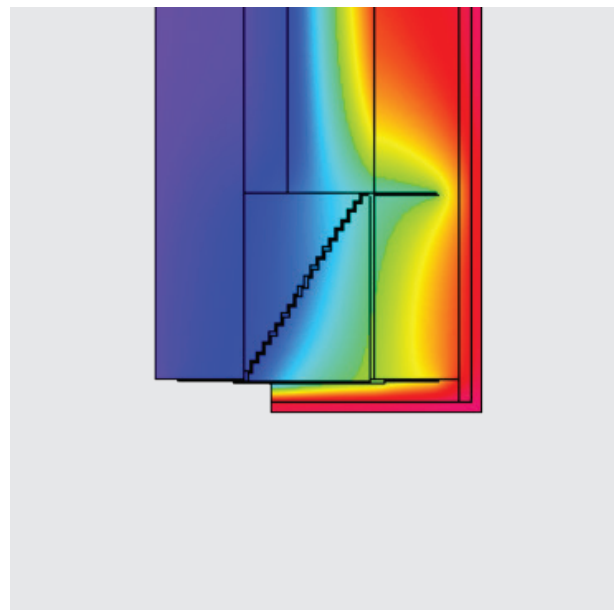
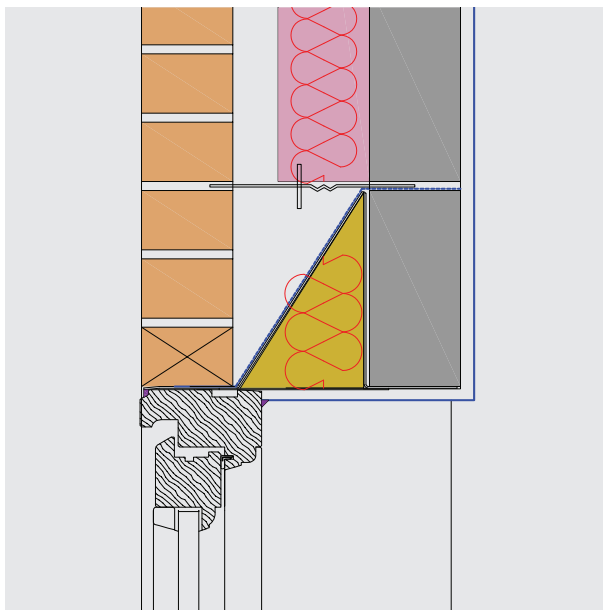

Description	Internal blockwork conductivity (W/mK)				
	0.11	0.15	0.19	0.51	1.13
U-value achieved (W/m ² K)	0.14	0.15	0.15	0.16	0.16
Linear thermal transmittance Ψ (W/mK)	0.341	0.350	0.357	0.390	0.420
Temperature factor (f)	0.84	0.84	0.84	0.85	0.85

NB Calculation modelled with 30 mm overlap

E1 – Open back lintel (insulated) with perforated steel base plate

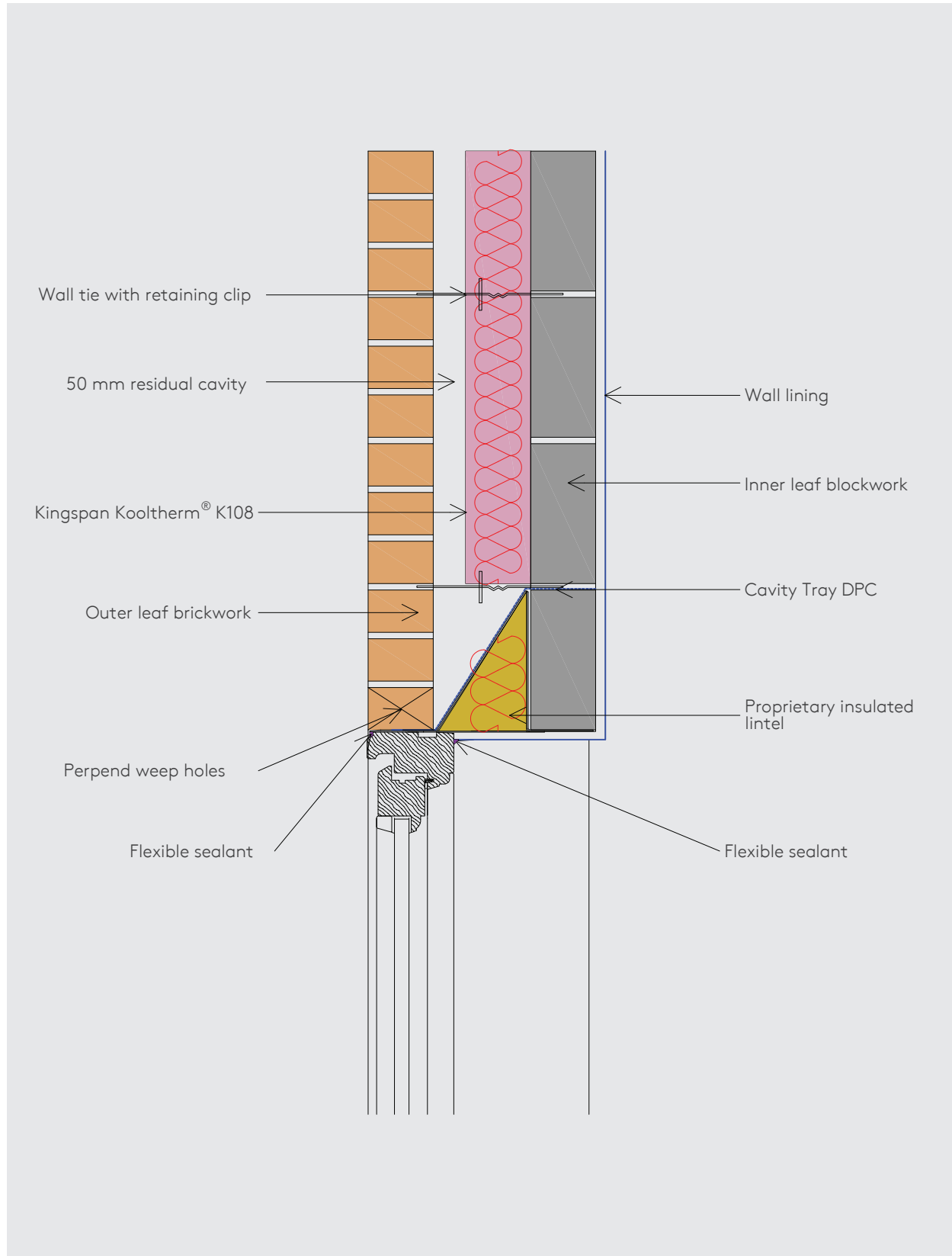

E1 – Open back lintel (insulated) with perforated steel base plate - insulated reveal

General construction specification

- Wall lining (12.5 mm plasterboard on dabs)
- Inner leaf blockwork
- 150 mm overall cavity width with 100 mm Kingspan Kooltherm® K108 Cavity Board and 50 mm cavity
- Outer leaf brickwork

Thermal performance process sequence

- Ensure Kingspan Kooltherm® K108 is in contact with the lintel.
- Ensure there are no gaps between the insulation boards.
- For normal reveals, ensure the window / door frame overlaps the lintel by no less than 30 mm.
- Kingspan Kooltherm® K108 should be firmly held against the inner leaf of blockwork.
- The cavity and wall ties should be kept clean of mortar and other debris during construction.

Air barrier process sequence

- Apply flexible sealant to all interfaces between the internal air barrier and the window / door frame.
- Seal all penetrations through the air barrier using a flexible sealant.
- Seal the joint between the window frame and the internal linings.
- 37.5 mm Kingspan Kooltherm® K118 Insulated Plasterboard added to the window reveal with adhesive and supplementary fixings. Ensure Kingspan Kooltherm® K118 butts the window frame. Seal the perimeter with flexible sealant.

Detail

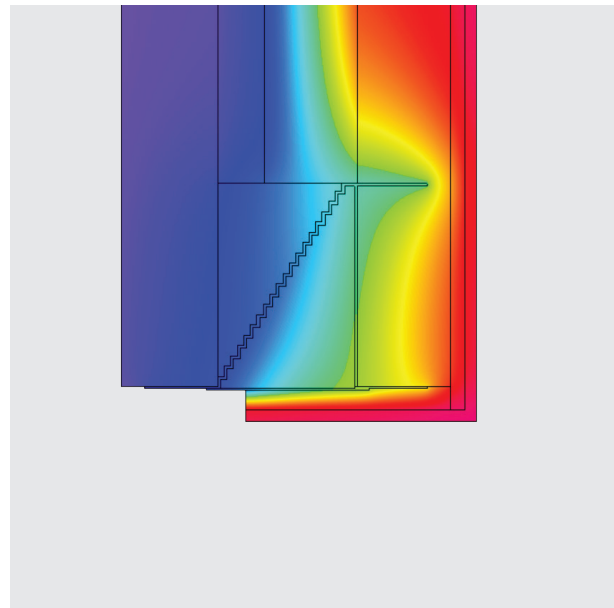
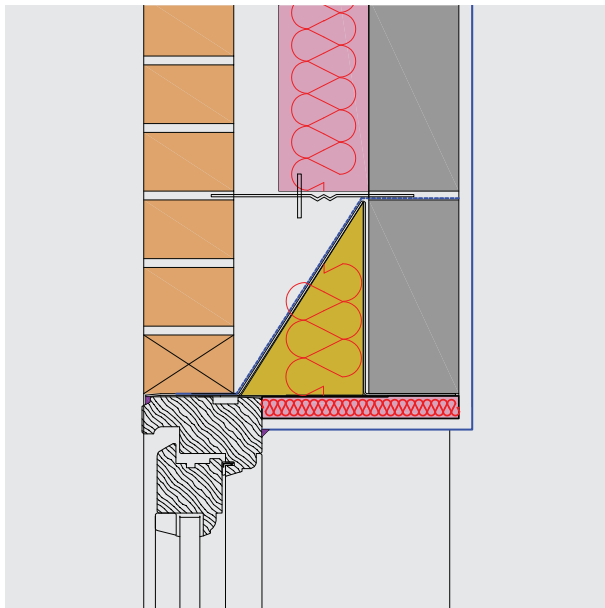

Description	Internal blockwork conductivity (W/mK)				
	0.11	0.15	0.19	0.51	1.13
U-value achieved (W/m ² K)	0.14	0.15	0.15	0.16	0.16
Linear thermal transmittance Ψ (W/mK)	0.253	0.267	0.277	0.320	0.357
Temperature factor (f)	0.93	0.92	0.92	0.91	0.90

NB Calculation modelled with 30 mm overlap

E1 – Open back lintel (insulated) with perforated steel base plate and insulated reveal

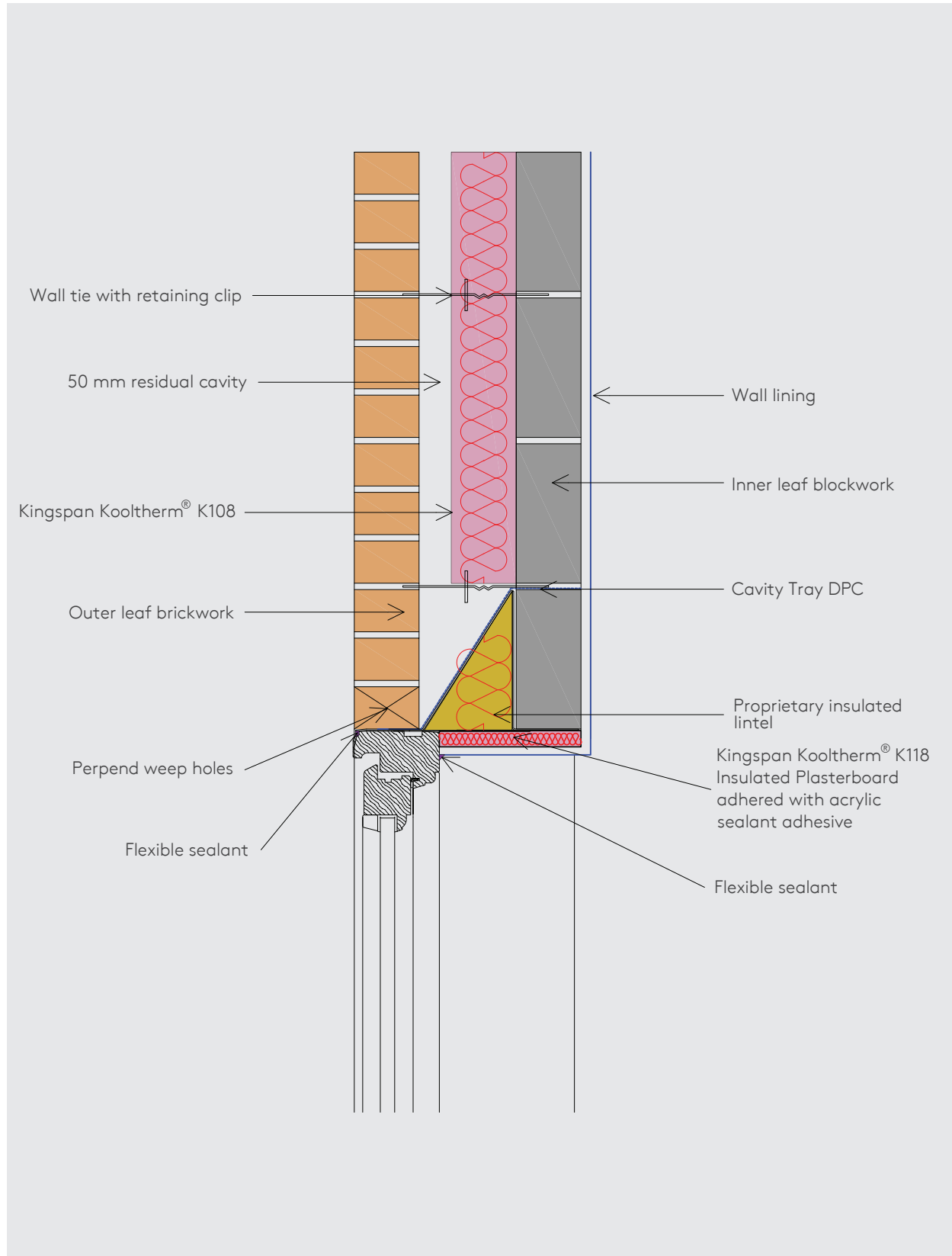

E3 - Sill (un-insulated reveal)

General construction specification

- Wall lining (12.5 mm plasterboard on dabs)
- Inner leaf blockwork
- 150 mm overall cavity width with 100 mm Kingspan Kooltherm® K108 Cavity Board and 50 mm cavity
- Outer leaf brickwork

Thermal performance process sequence

- Kingspan Kooltherm® Cavity Closer should be installed to close the cavity.
- Ensure Kingspan Kooltherm® K108 is lightly butted up against the Kingspan Kooltherm® Cavity Closer so that there are no gaps between the two products.
- Ensure there are no gaps between the insulation boards.
- For normal reveals, ensure the window / door frame overlaps Kingspan Kooltherm® Cavity Closer by no less than 30 mm.
- Kingspan Kooltherm® K108 should be firmly held against the inner leaf of blockwork.
- The cavity and wall ties should be kept clean of mortar and other debris during construction.

Air barrier process sequence

- Apply flexible sealant to all interfaces between the internal air barrier and the window / door frame.
- Seal all penetrations through the air barrier using a flexible sealant.
- Seal the joint between the window frame and the internal linings.
- Seal the junction between the window sill board and the window frame member.

Detail

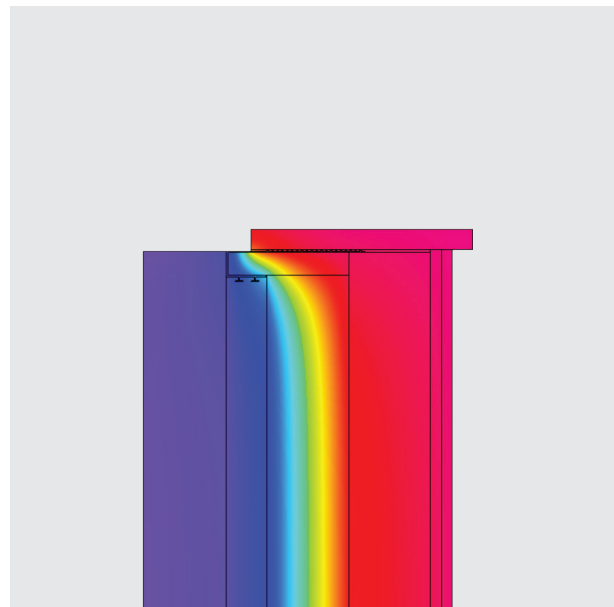
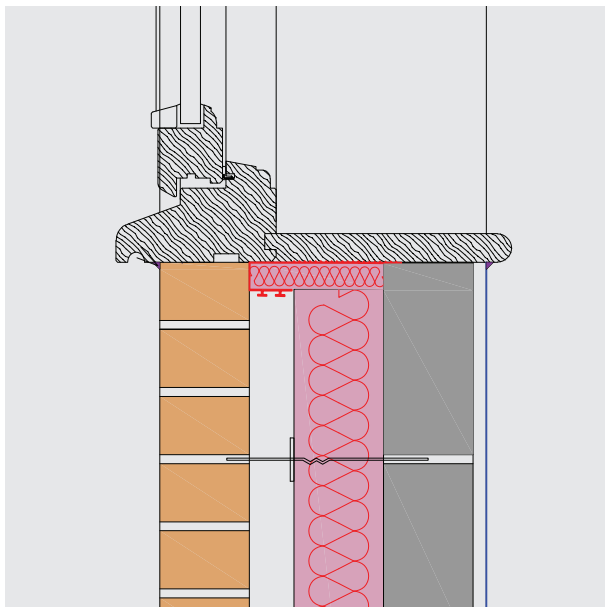

Description	Internal blockwork conductivity (W/mK)				
	0.11	0.15	0.19	0.51	1.13
U-value achieved (W/m²K)	0.14	0.15	0.15	0.16	0.16
Linear thermal transmittance Ψ (W/mK)	0.021	0.021	0.021	0.020	0.020
Temperature factor (f)	0.91	0.91	0.91	0.91	0.91

NB Calculation modelled with 30 mm overlap

E3 - Sill (un-insulated reveal)

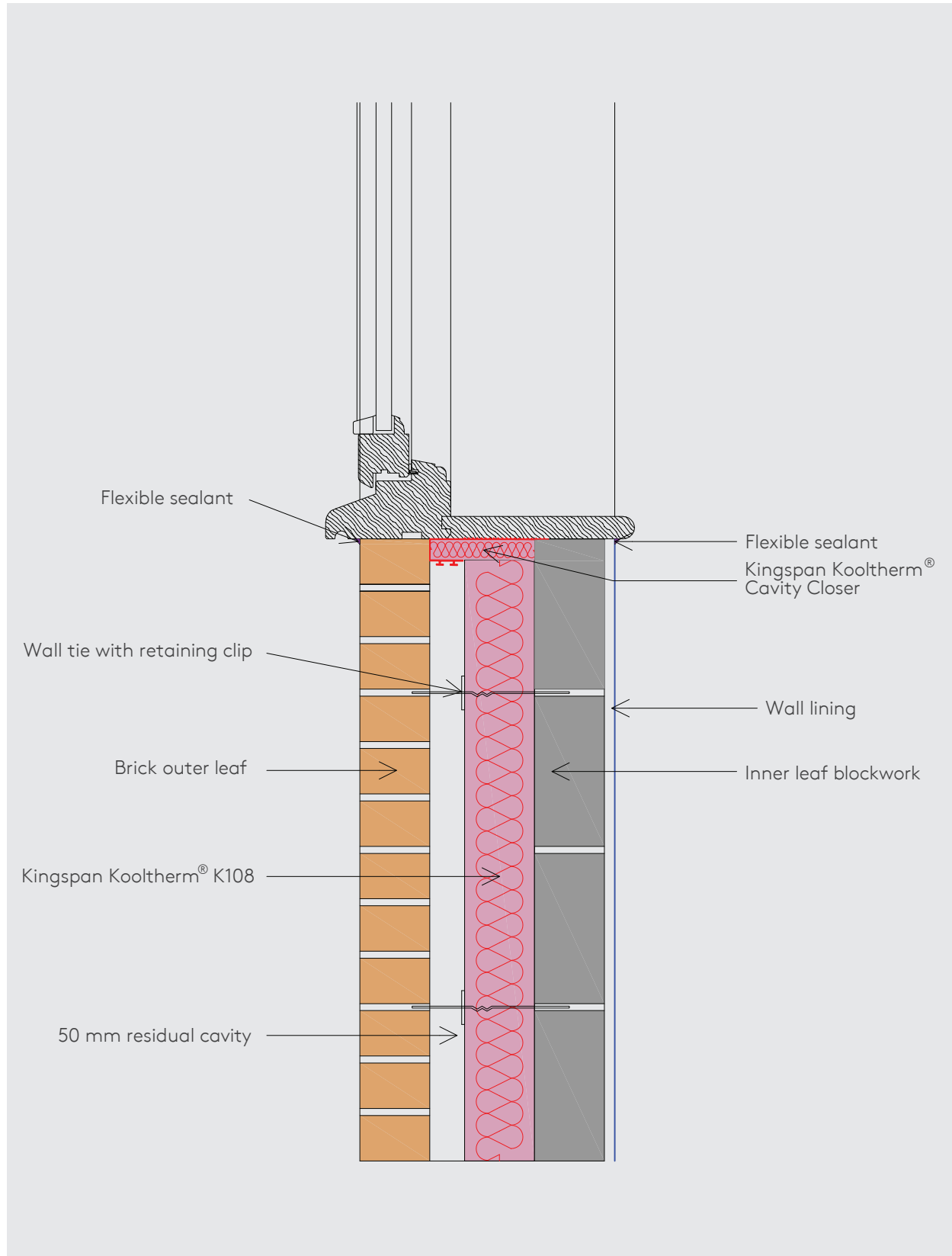

E3 - Sill (insulated reveal)

General construction specification

- Wall lining (12.5 mm plasterboard on dabs)
- Inner leaf blockwork
- 150 mm overall cavity width with 100 mm Kingspan Kooltherm® K108 Cavity Board and 50 mm cavity
- Outer leaf brickwork

Thermal performance process sequence

- Kingspan Kooltherm® Cavity Closer should be installed to close the cavity.
- Ensure Kingspan Kooltherm® K108 is lightly butted up against the Kingspan Kooltherm Cavity Closer so that there are no gaps between the two products.
- Ensure there are no gaps between the insulation boards.
- For normal reveals, ensure the window / door frame overlaps Kingspan Kooltherm® Cavity Closer by no less than 30 mm.
- Kingspan Kooltherm® K108 should be firmly held against the inner leaf of blockwork.
- The cavity and wall ties should be kept clean of mortar and other debris during construction.

Air barrier process sequence

- 37.5 mm Kingspan Kooltherm® K118 added to the window reveal with adhesive and supplementary fixings. Ensure Kingspan Kooltherm® K118 butts the window frame. Seal the perimeter with flexible sealant.
- Apply flexible sealant to all interfaces between the internal air barrier and the window / door frame.
- Seal all penetrations through the air barrier using a flexible sealant.
- Seal the joint between the window frame and the internal linings.
- Seal the junction between the window sill board and the window frame member.

Detail

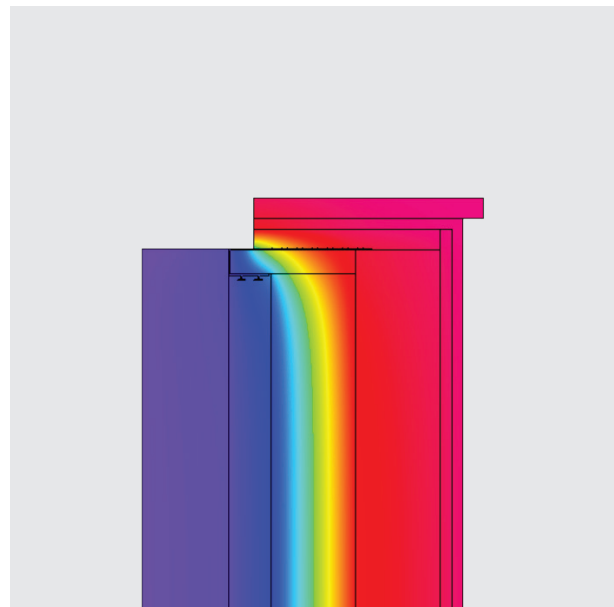
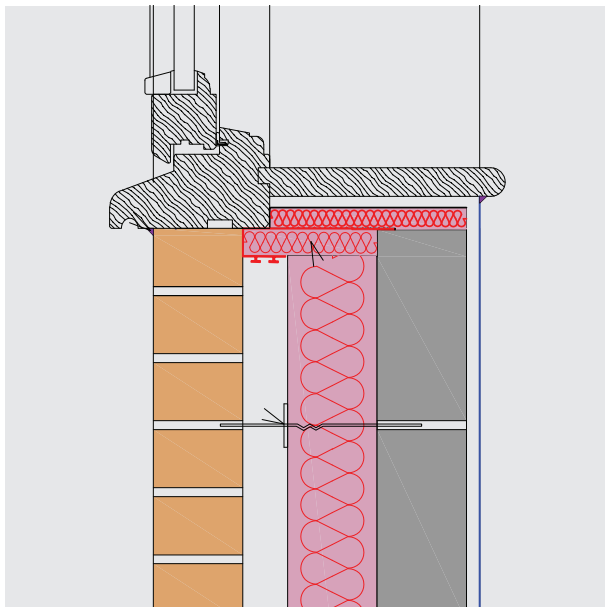

Description	Internal blockwork conductivity (W/mK)				
	0.11	0.15	0.19	0.51	1.13
U-value achieved (W/m ² K)	0.14	0.15	0.15	0.16	0.16
Linear thermal transmittance Ψ (W/mK)	0.006	0.006	0.006	0.005	0.005
Temperature factor (f)	0.96	0.96	0.96	0.97	0.97

NB Calculation modelled with 30 mm overlap

E3 - Sill (insulated reveal)

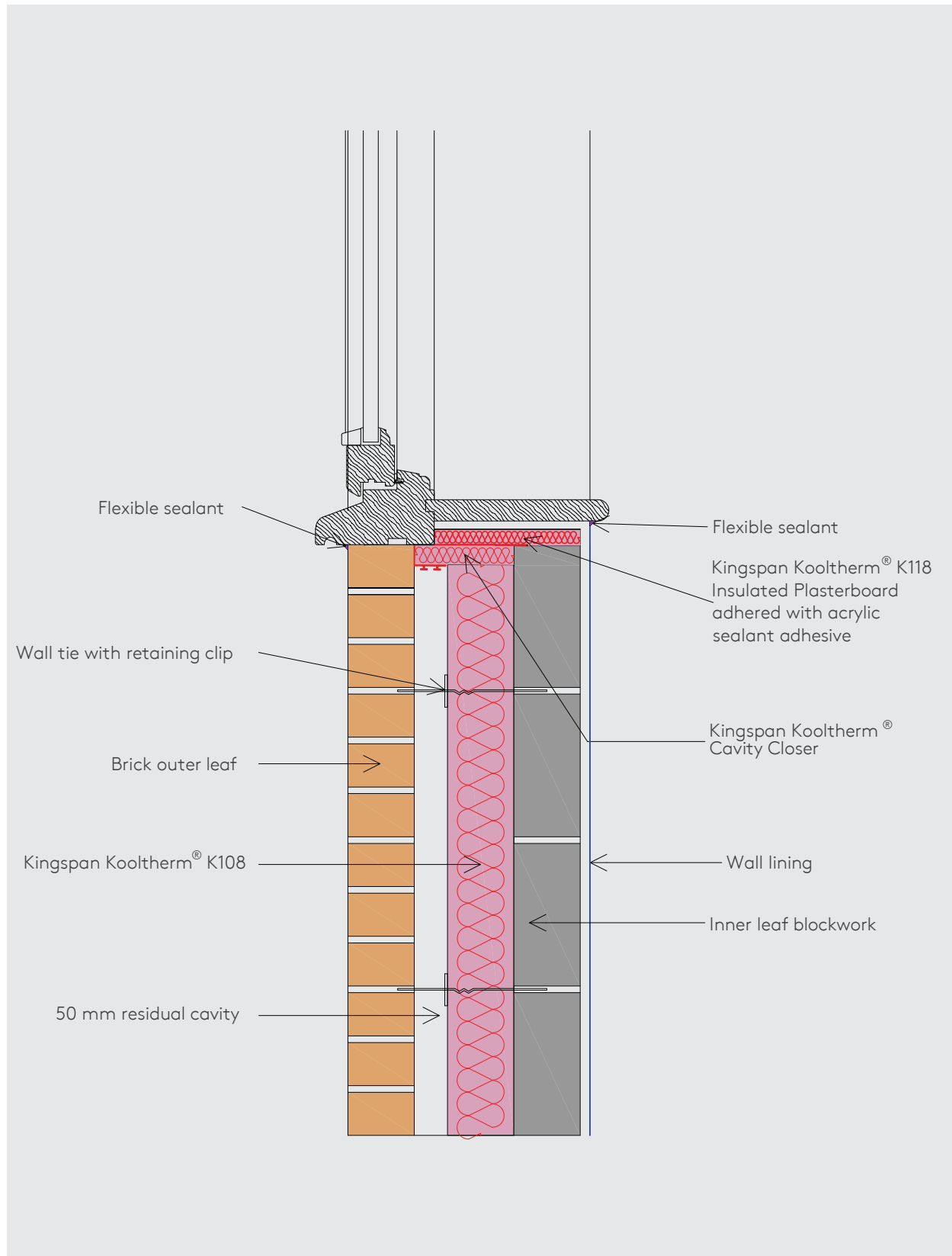

E4 - Jamb (un-insulated reveal)

General construction specification

- Wall lining (12.5 mm plasterboard on dabs)
- Inner leaf blockwork
- 150 mm overall cavity width with 100 mm Kingspan Kooltherm® K108 Cavity Board and 50 mm cavity
- Outer leaf brickwork

Thermal performance process sequence

- Kingspan Kooltherm® Cavity Closer should be installed to close the cavity.
- Ensure Kingspan Kooltherm® K108 is lightly butted up against the Kingspan Kooltherm® Cavity Closer so that there are no gaps between the two products.
- Ensure there are no gaps between the insulation boards.
- For normal reveals, ensure the window / door frame overlaps Kingspan Kooltherm® Cavity Closer by no less than 30 mm.
- Kingspan Kooltherm® K108 should be firmly held against the inner leaf of blockwork.
- The cavity and wall ties should be kept clean of mortar and other debris during construction.

- At the vertical edges of openings and at vertical unreturned or unbounded edges (e.g. movement joints), additional wall ties should be used at a rate of one tie per 300 mm height or equivalent, placed not more than 225 mm from the edge.
- Alternatively, use an additional wall tie within 225 mm of the opening / vertical edge on each board course (450 mm) level to satisfy the structural requirements of the wall. Avoid penetrating the board, as this may introduce an unacceptable risk of water penetration. Place additional ties on each board course to compensate.

Air barrier process sequence

- Apply flexible sealant to all interfaces between the internal air barrier and the window / door frame.
- Seal all penetrations through the air barrier using a flexible sealant.
- Seal the junction between the window sill board and the window frame member.

Detail

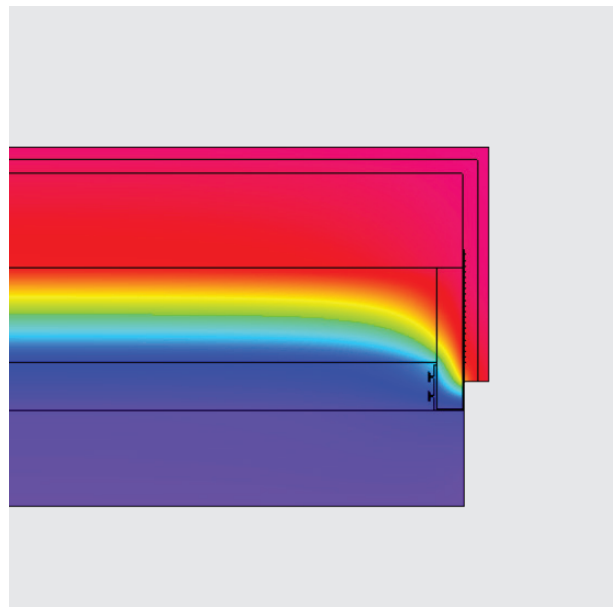
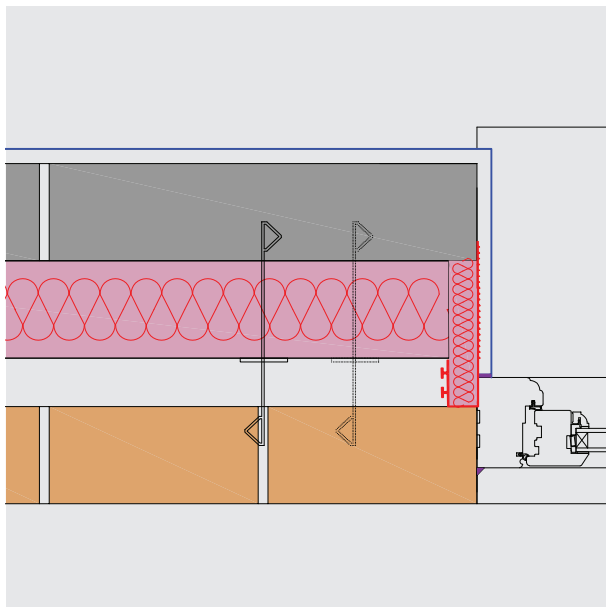

Description	Internal blockwork conductivity (W/mK)				
	0.11	0.15	0.19	0.51	1.13
U-value achieved (W/m²K)	0.14	0.15	0.15	0.16	0.16
Linear thermal transmittance Ψ (W/mK)	0.022	0.022	0.022	0.021	0.021
Temperature factor (f)	0.93	0.93	0.93	0.93	0.93

NB Calculation modelled with 30 mm overlap

E4 - Jamb (un-insulated reveal)

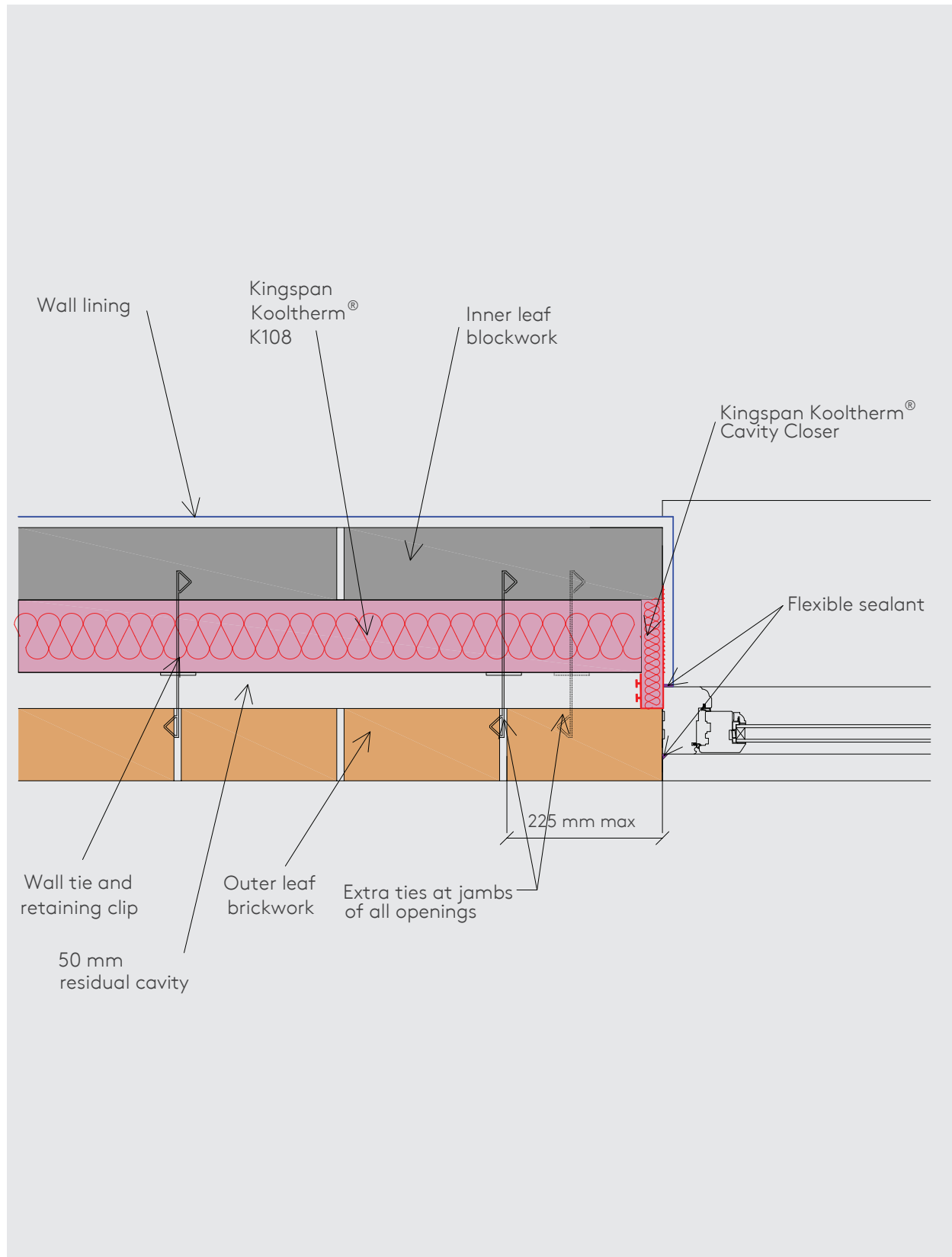

E4 - Jamb (insulated reveal)

General construction specification

- Wall lining (12.5 mm plasterboard on dabs)
- Inner leaf blockwork
- 150 mm overall cavity width with 100 mm Kingspan Kooltherm® K108 Cavity Board and 50 mm cavity
- Outer leaf brickwork

Thermal performance process sequence

- Kingspan Kooltherm® Cavity Closer should be installed to close the cavity.
- Ensure Kingspan Kooltherm® K108 is lightly butted up against the Kingspan Kooltherm® Cavity Closer so that there are no gaps between the two products.
- Ensure there are no gaps between the insulation boards.
- For normal reveals, ensure the window / door frame overlaps Kingspan Kooltherm® Cavity Closer by no less than 30 mm.
- Kingspan Kooltherm® K108 should be firmly held against the inner leaf of blockwork.
- The cavity and wall ties should be kept clean of mortar and other debris during construction.

- At the vertical edges of openings and at vertical unreturned or unbounded edges (e.g. movement joints), additional wall ties should be used at a rate of one tie per 300 mm height or equivalent, placed not more than 225 mm from the edge.
- Alternatively, use an additional wall tie within 225 mm of the opening / vertical edge on each board course (450 mm) level to satisfy the structural requirements of the wall. Avoid penetrating the board, as this may introduce an unacceptable risk of water penetration. Place additional ties on each board course to compensate.

Air barrier process sequence

- 37.5 mm Kingspan Kooltherm® K118 added to the window reveal with adhesive and supplementary fixings. Ensure Kingspan Kooltherm® K118 butts the window frame. Seal the perimeter with flexible sealant.
- Apply flexible sealant to all interfaces between the internal air barrier and the window / door frame.
- Seal all penetrations through the air barrier using a flexible sealant.
- Seal the junction between the window sill board and the window frame member.

Detail

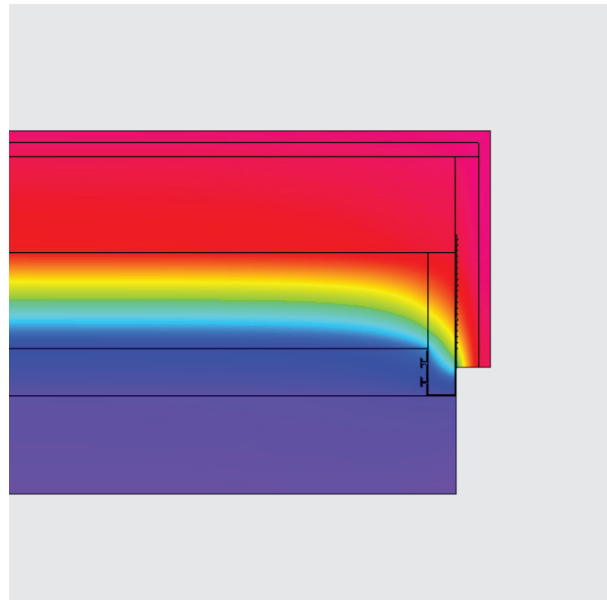
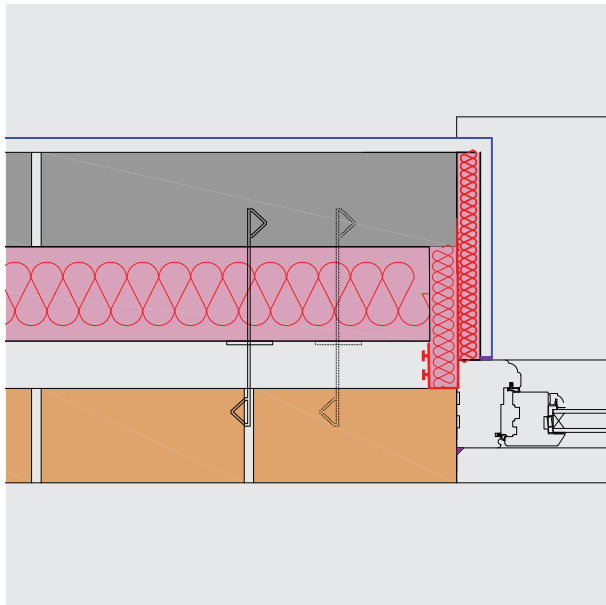

Description	Internal blockwork conductivity (W/mK)				
	0.11	0.15	0.19	0.51	1.13
U-value achieved (W/m²K)	0.14	0.15	0.15	0.16	0.16
Linear thermal transmittance Ψ (W/mK)	0.011	0.010	0.010	0.010	0.009
Temperature factor (f)	0.96	0.96	0.96	0.96	0.96

NB Calculation modelled with 30 mm overlap

E4 - Jamb (insulated reveal)

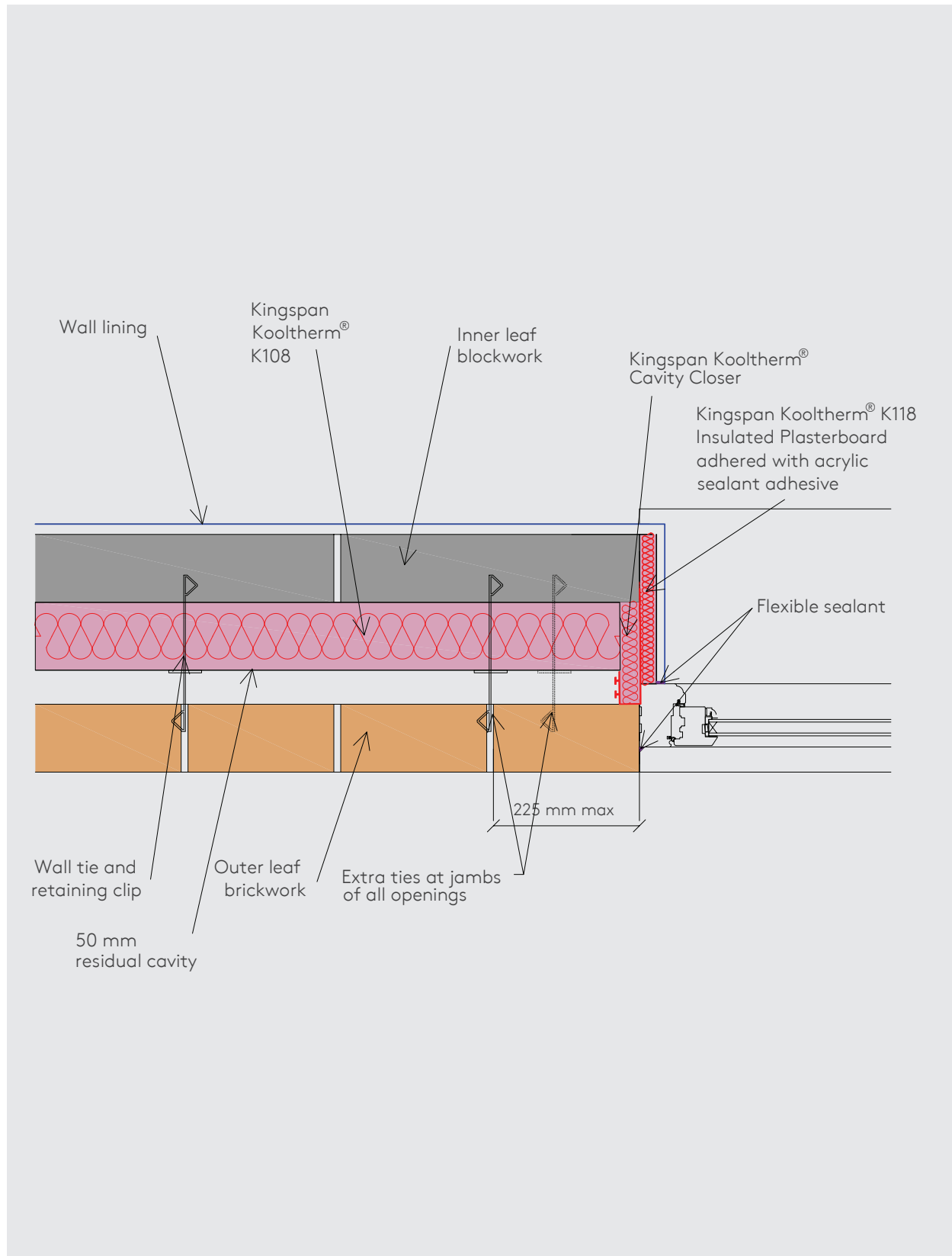

E5 - Ground floor (solid concrete slab)

General construction specification

- Wall lining (12.5 mm plasterboard on dabs)
- Inner leaf blockwork
- 150 mm overall cavity width with 100 mm Kingspan Kooltherm® K108 Cavity Board and 50 mm cavity
- Outer leaf brickwork

Air barrier process sequence

- Apply flexible sealant between wall lining and floor lining.
- Apply flexible sealant between the skirting board and the floor screed / finish.
- Seal all penetrations through the air barrier using a flexible sealant.

Thermal performance process sequence

- Install 25 mm (minimum) Kingspan Kooltherm® K103 Floorboard vertically around the perimeter of the floor. Install the upstand insulation so that it is flush with the floor screed. Kingspan Kooltherm® K103 or vertical perimeter insulation must tightly abut the inner leaf of blockwork.
- Kingspan Kooltherm® K108 should be firmly held against the inner leaf of blockwork.
- Ensure Kingspan Kooltherm® K108 is installed at least 150 mm below the top surface of the Kingspan Kooltherm® K103 perimeter insulation.
- The cavity and wall ties should be kept clean of mortar and other debris during construction.
- Ensure all Kingspan Kooltherm® K108 joints are lightly butted.

Detail

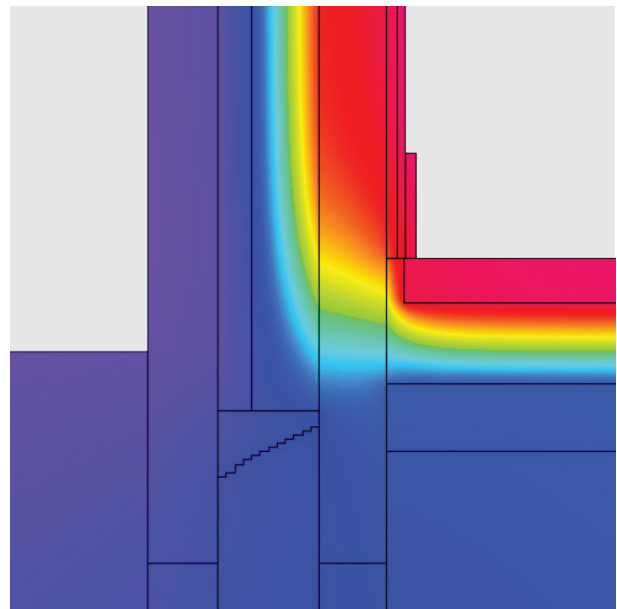
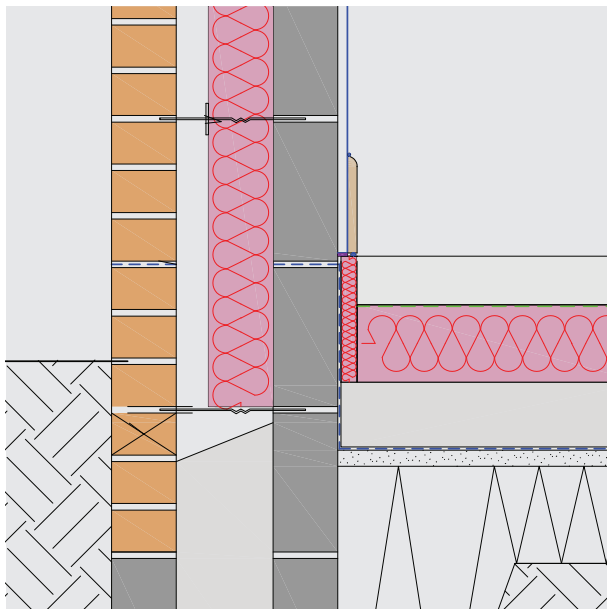

Description	Internal blockwork conductivity (W/mK)				
	0.11	0.15	0.19	0.51	1.13
U-value achieved (W/m ² K)	0.14	0.15	0.15	0.16	0.16
Linear thermal transmittance Ψ (W/mK)	0.047	0.054	0.060	0.098	0.162
Temperature factor (f)	0.95	0.95	0.94	0.94	0.92

NB Calculations based on 120 mm Kingspan Kooltherm® K103 insulation. Cavity fill thermal conductivity taken as 1.4 W/mK (concrete).

E5 - Ground floor (solid concrete slab)

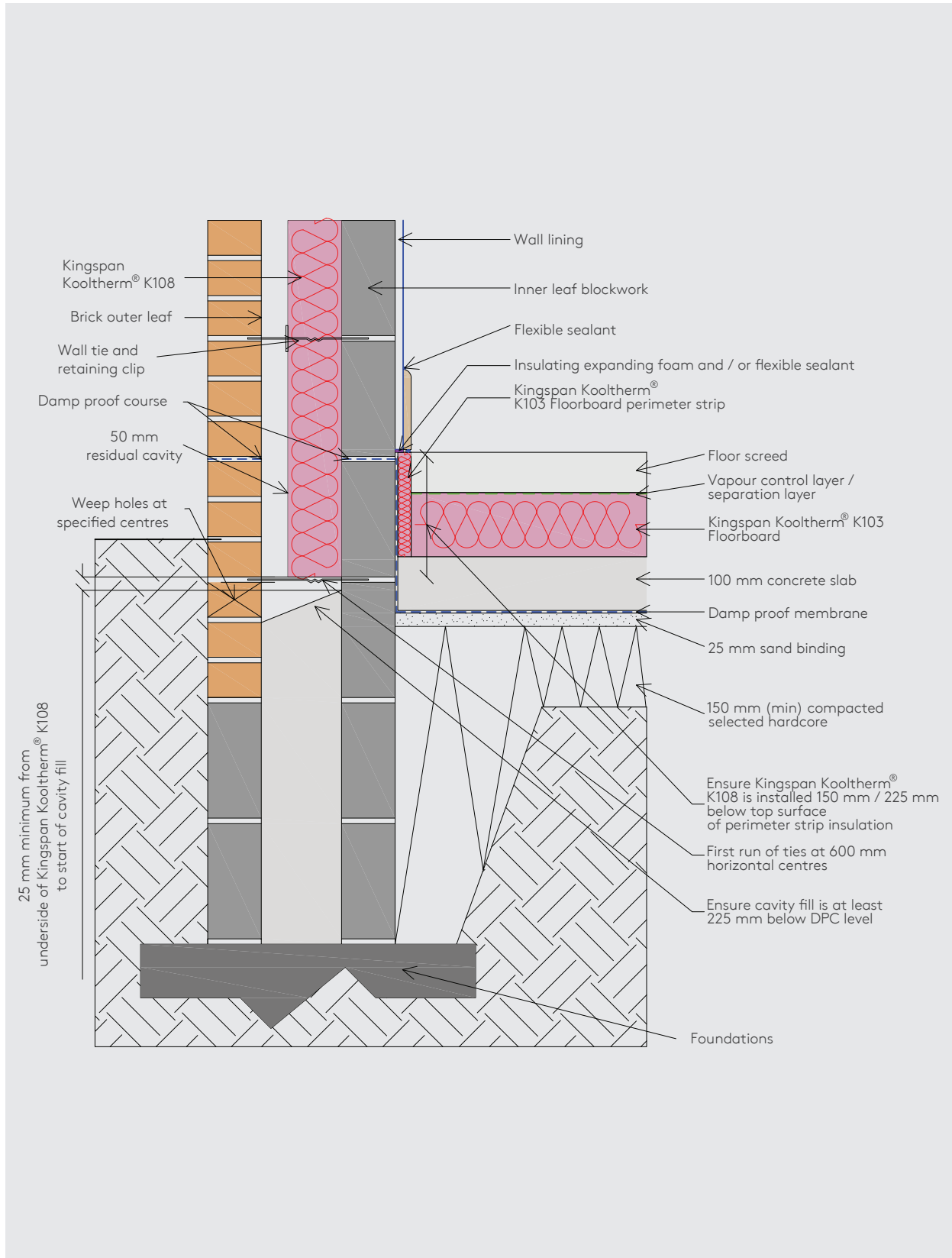

E5 - Ground floor (beam & block - perpendicular)

General construction specification

- Wall lining (12.5 mm plasterboard on dabs)
- Inner leaf blockwork
- 150 mm overall cavity width with 100 mm Kingspan Kooltherm® K108 Cavity Board and 50 mm cavity
- Outer leaf brickwork

Air barrier process sequence

- Apply flexible sealant between wall lining and floor lining.
- Apply flexible sealant between the skirting board and the floor screed / finish.
- Seal all penetrations through the air barrier using a flexible sealant.

Thermal performance process sequence

- Install 25 mm (minimum) Kingspan Kooltherm® K103 vertically around the perimeter of the floor. Install the upstand insulation so that it is flush with the floor screed. Kingspan Kooltherm® K103 or vertical perimeter insulation must tightly abut the inner leaf of blockwork.
- Kingspan Kooltherm® K108 Cavity Board should be firmly held against the inner leaf of blockwork.
- Ensure Kingspan Kooltherm® K108 is installed at least 150 mm below the top surface of the Kingspan Kooltherm® K103 perimeter insulation.
- The cavity and wall ties should be kept clean of mortar and other debris during construction.
- Ensure all Kingspan Kooltherm® K108 joints are lightly butted.

Detail

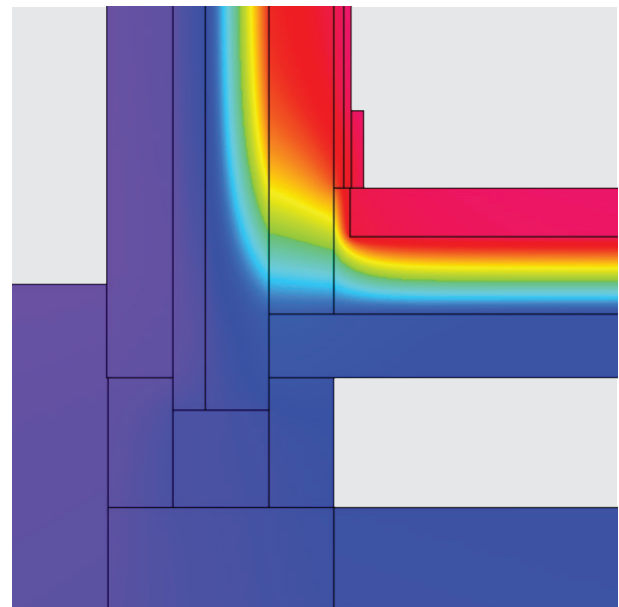
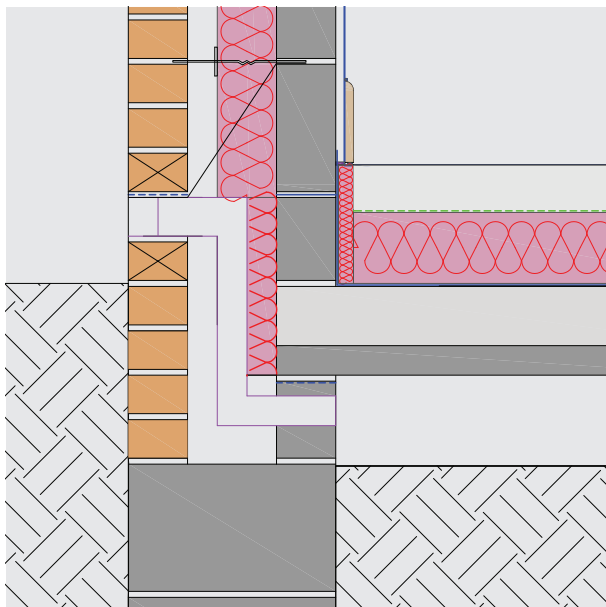

Description	Internal blockwork conductivity (W/mK)				
	0.11	0.15	0.19	0.51	1.13
U-value achieved (W/m ² K)	0.14	0.15	0.15	0.16	0.16
Linear thermal transmittance Ψ (W/mK)	0.054	0.060	0.069	0.112	0.179
Temperature factor (f)	0.94	0.94	0.94	0.93	0.91

NB Calculations based on 120 mm Kingspan Kooltherm® K103 insulation. Trench block thermal conductivity taken as 0.24 W/mK.

E5 - Ground floor (beam & block - perpendicular)

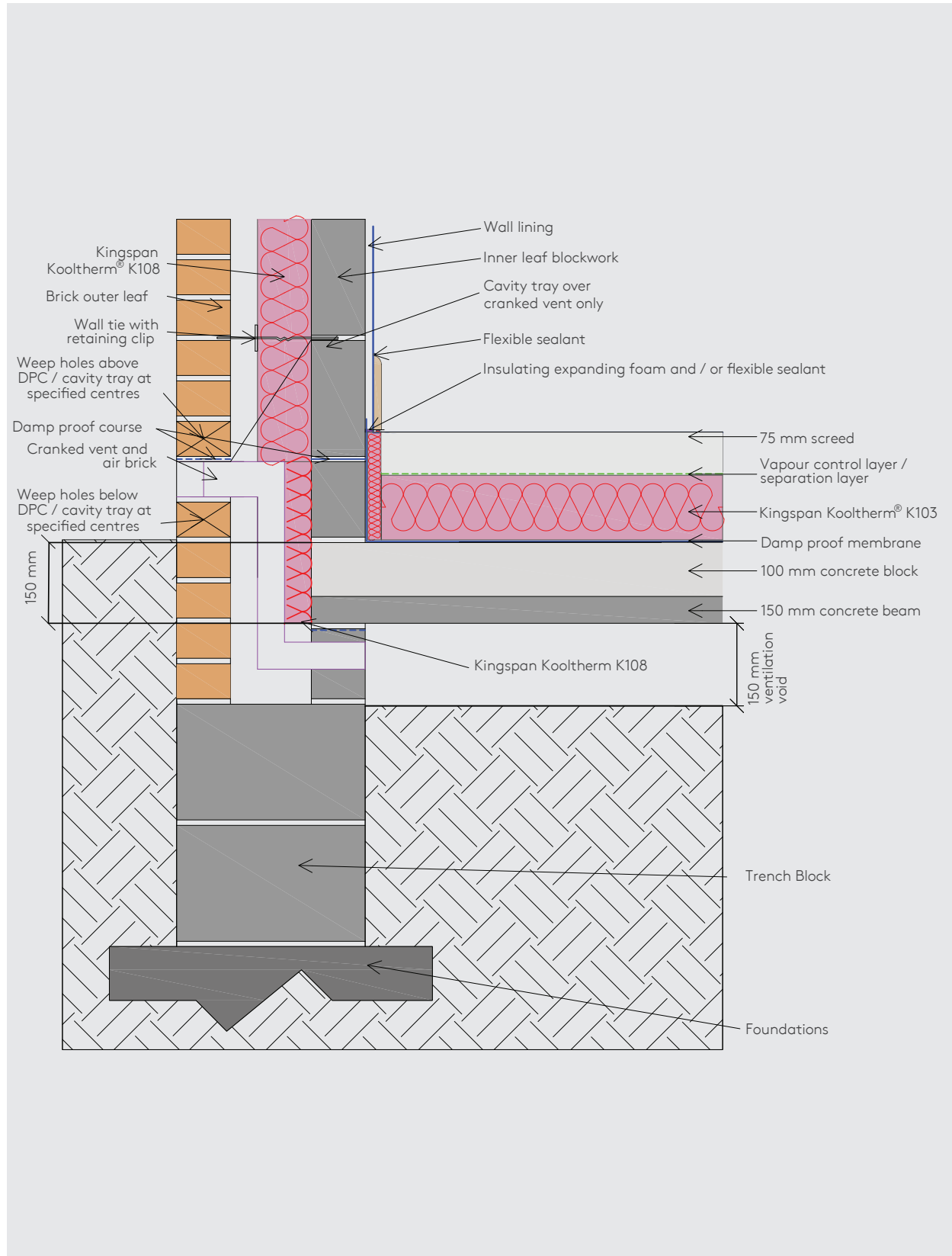

E5 - Ground floor (beam & block - parallel)

General construction specification

- Wall lining (12.5 mm plasterboard on dabs)
- Inner leaf blockwork
- 150 mm overall cavity width with 100 mm Kingspan Kooltherm® K108 Cavity Board and 50 mm cavity
- Outer leaf brickwork

Air barrier process sequence

- Apply flexible sealant between wall lining and floor lining.
- Apply flexible sealant between the skirting board and the floor screed / finish.
- Seal all penetrations through the air barrier using a flexible sealant.

Thermal performance process sequence

- Install 25 mm (minimum) Kingspan Kooltherm® K103 Floorboard vertically around the perimeter of the floor. Install the upstand insulation so that it is flush with the floor screed. Kingspan Kooltherm® K103 or vertical perimeter insulation must tightly abut the inner leaf of blockwork.
- Kingspan Kooltherm® K108 should be firmly held against the inner leaf of blockwork.
- Ensure Kingspan Kooltherm® K108 is installed at least 150 mm below the top surface of the Kingspan Kooltherm® K103 perimeter insulation.
- The cavity and wall ties should be kept clean of mortar and other debris during construction.
- Ensure all Kingspan Kooltherm® K108 joints are lightly butted.

Detail

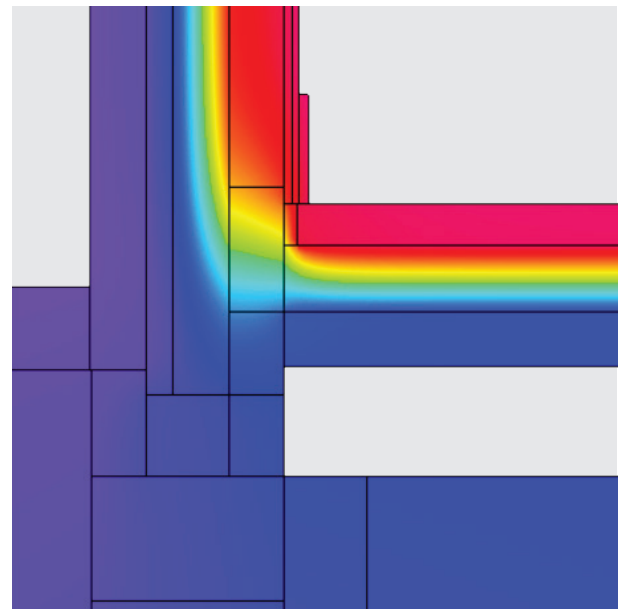
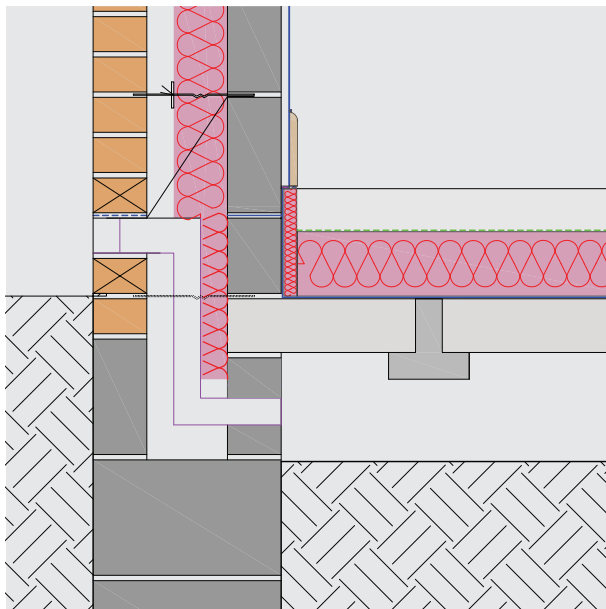

Description	Internal blockwork conductivity (W/mK)				
	0.11	0.15	0.19	0.51	1.13
U-value achieved (W/m ² K)	0.14	0.15	0.15	0.16	0.16
Linear thermal transmittance Ψ (W/mK)	0.053	0.060	0.066	0.109	0.180
Temperature factor (f)	0.94	0.94	0.94	0.93	0.92

NB Calculations based on 120 mm Kingspan Kooltherm® K103 insulation. Trench block thermal conductivity taken as 0.24 W/mK.

E5 - Ground floor (beam & block - parallel)

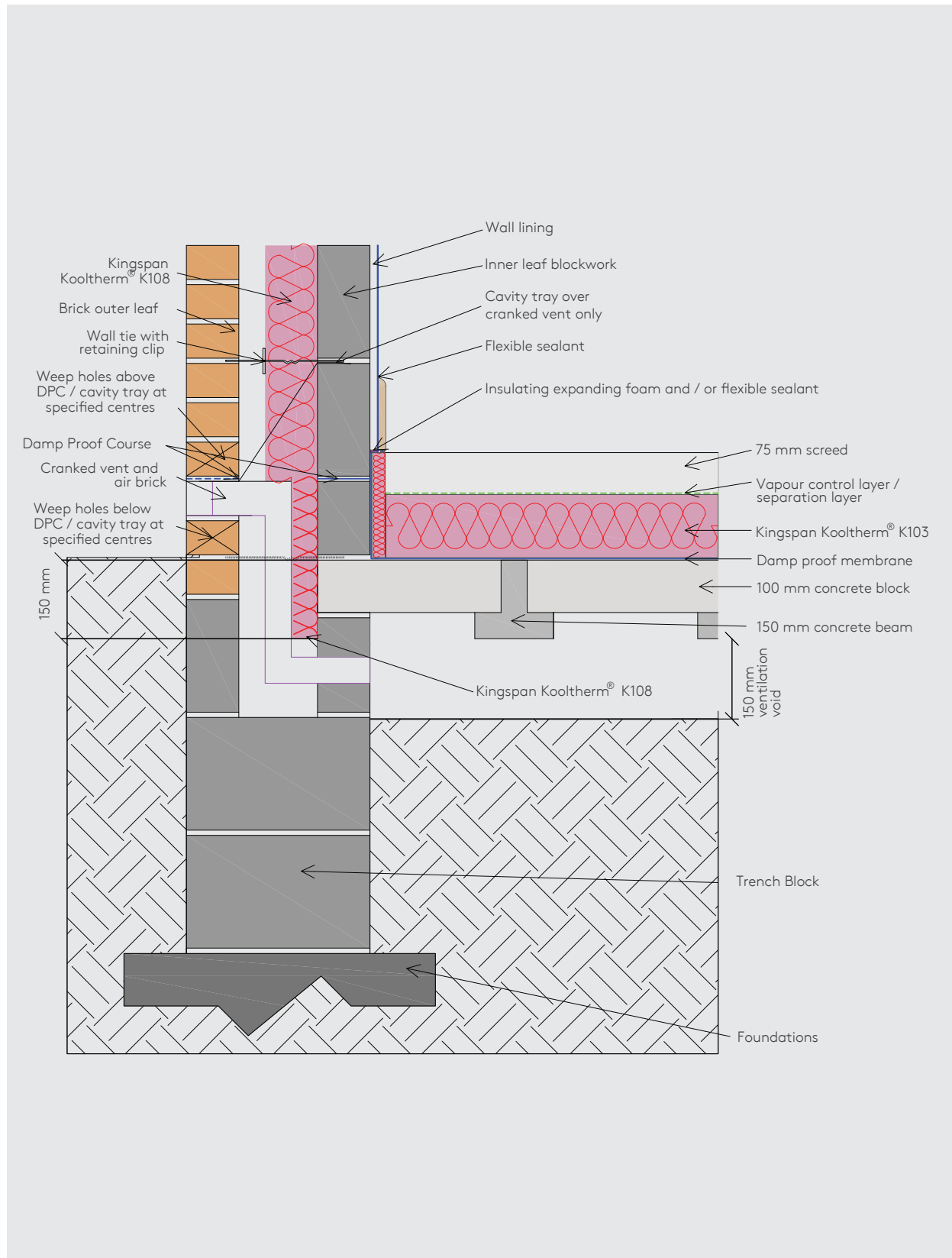

E5 - Ground floor (suspended timber floor)

General construction specification

- Wall lining (12.5 mm plasterboard on dabs)
- Inner leaf blockwork
- 150 mm overall cavity width with 100 mm Kingspan Kooltherm® K108 Cavity Board and 50 mm cavity
- Outer leaf brickwork

Thermal performance process sequence

- Install 25 mm (minimum) Kingspan Kooltherm® K103 Floorboard vertically around the perimeter of the floor. Install the upstand insulation so that it is flush with the floor screed. Kingspan Kooltherm® K103 or vertical perimeter insulation must tightly abut the inner leaf of blockwork.
- Kingspan Kooltherm® K108 should be firmly held against the inner leaf of blockwork.
- Ensure Kingspan Kooltherm® K108 is installed at least 150 mm below the top surface of the Kingspan Kooltherm® K103 perimeter insulation.
- The cavity and wall ties should be kept clean of mortar and other debris during construction.
- Ensure all Kingspan Kooltherm® K108 joints are lightly butted.

Air barrier process sequence

- Apply flexible sealant between wall lining and floor lining.
- Apply flexible sealant between the skirting board and the floor screed / finish.
- Seal all penetrations through the air barrier using a flexible sealant.

Detail

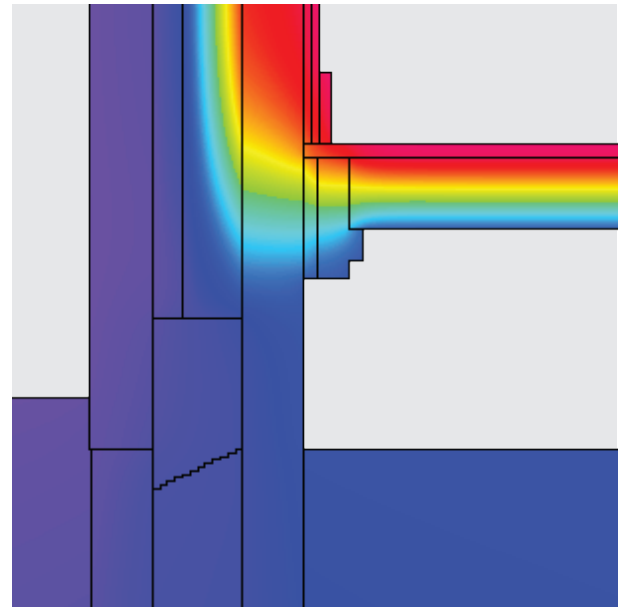
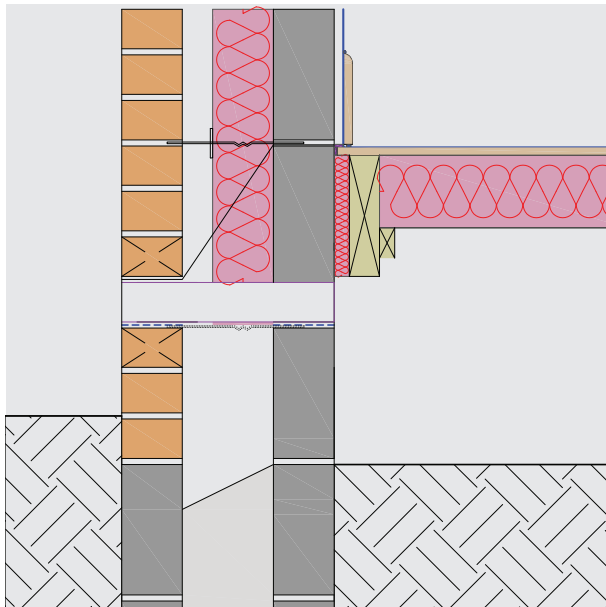

Description	Internal blockwork conductivity (W/mK)				
	0.11	0.15	0.19	0.51	1.13
U-value achieved (W/m ² K)	0.14	0.15	0.15	0.16	0.16
Linear thermal transmittance Ψ (W/mK)	0.060	0.067	0.073	0.113	0.185
Temperature factor (f)	0.89	0.88	0.88	0.87	0.92

NB Calculations based on 120 mm Kingspan Kooltherm® K103 insulation. Cavity fill thermal conductivity taken as 1.4 W/mK (concrete).

E5 - Ground floor (suspended timber floor)

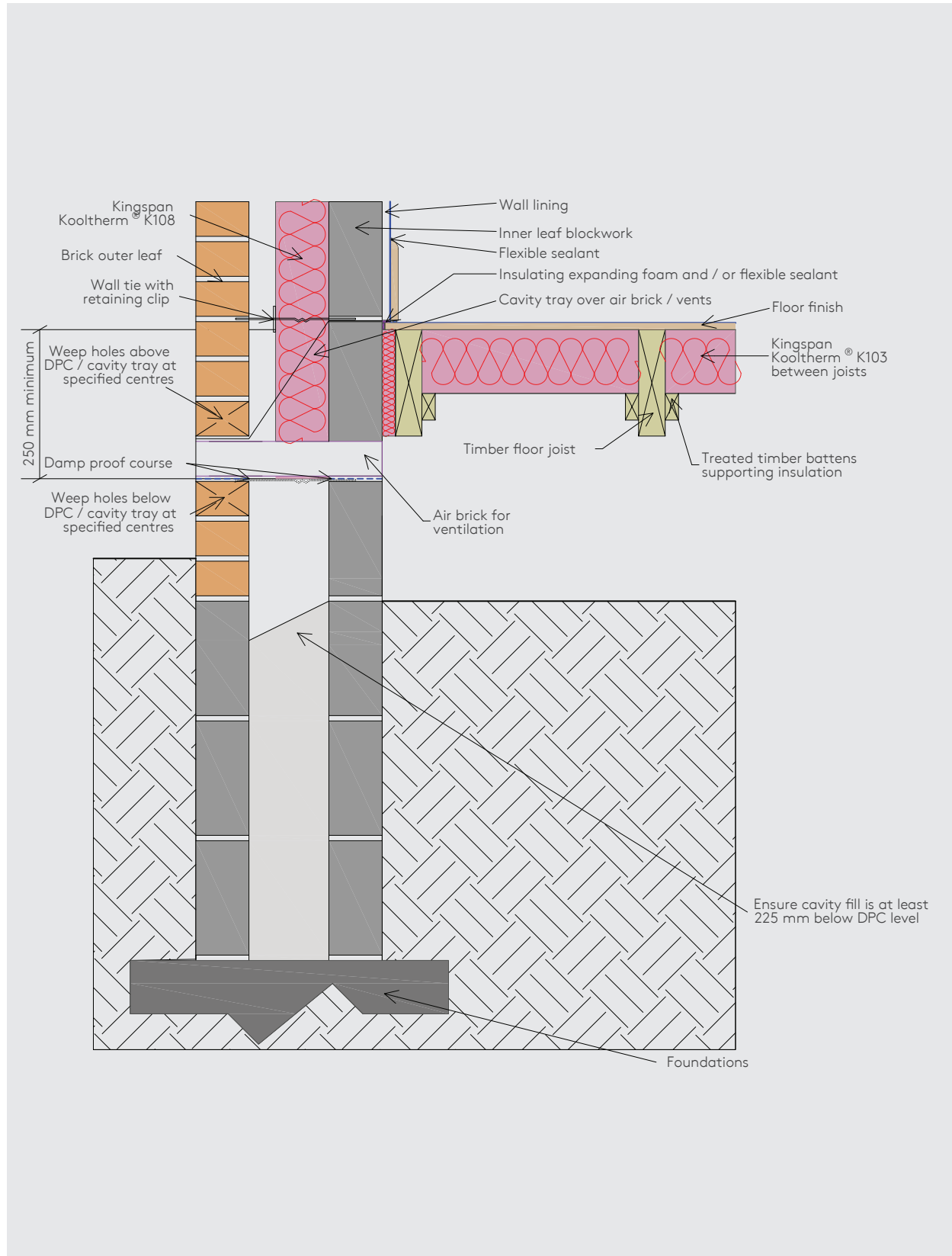

E6 - Intermediate floor (concrete)

General construction specification

- Wall lining (12.5 mm plasterboard on dabs)
- Inner leaf blockwork
- 150 mm overall cavity width with 100 mm Kingspan Kooltherm® K108 Cavity Board and 50 mm cavity
- Outer leaf brickwork

Thermal performance process sequence

- Kingspan Kooltherm® K108 should be firmly held against the inner leaf of blockwork.
- Continue Kingspan Kooltherm® K108 across the intermediate floor abutment zone.
- The cavity and wall ties should be kept clean of mortar and other debris during construction.
- Ensure there are no gaps between the insulation boards
- Ensure all Kingspan Kooltherm® K108 joints are lightly butted.

Air barrier process sequence

- Seal between the wall lining and floor screed lining with flexible sealant or plaster / screed mortar.
- Seal between the wall lining and ceiling lining with flexible sealant or plaster mortar.
- Apply flexible sealant between the skirting board and the floor screed / finish.
- Seal all penetrations through the air barrier using a flexible sealant or plaster mortar.
- Ensure a continuous bed of mortar between the floor slab and blockwork.

Detail

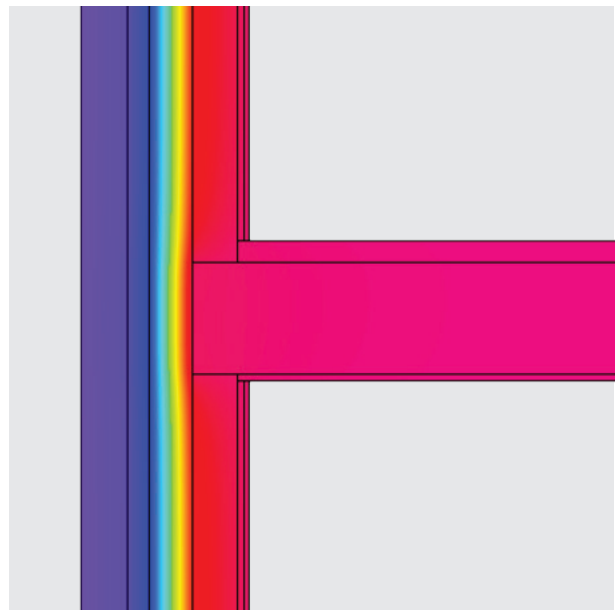
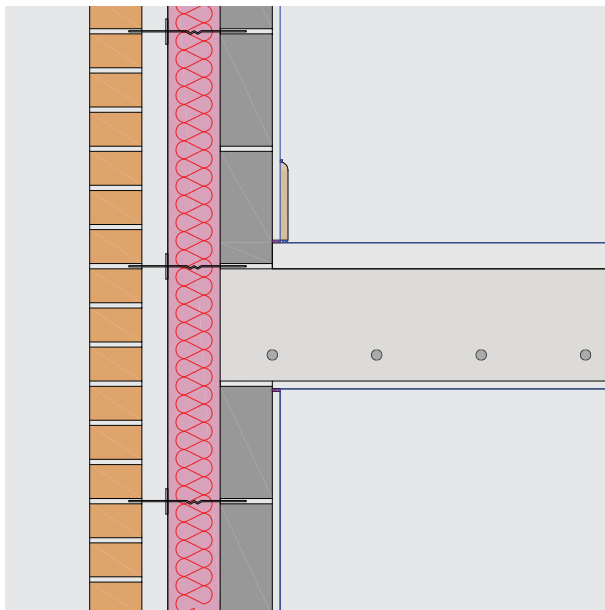

Description	Internal blockwork conductivity (W/mK)				
	0.11	0.15	0.19	0.51	1.13
U-value achieved (W/m ² K)	0.14	0.15	0.15	0.16	0.16
Linear thermal transmittance Ψ (W/mK)	0.007	0.006	0.005	0.004	0.003
Temperature factor (<i>f</i>)	0.98	0.98	0.98	0.98	0.98

NB Calculations based on 250 mm reinforced concrete intermediate floor. Ceiling lining to floor 15 mm dense plaster.

E6 - Intermediate floor (concrete)

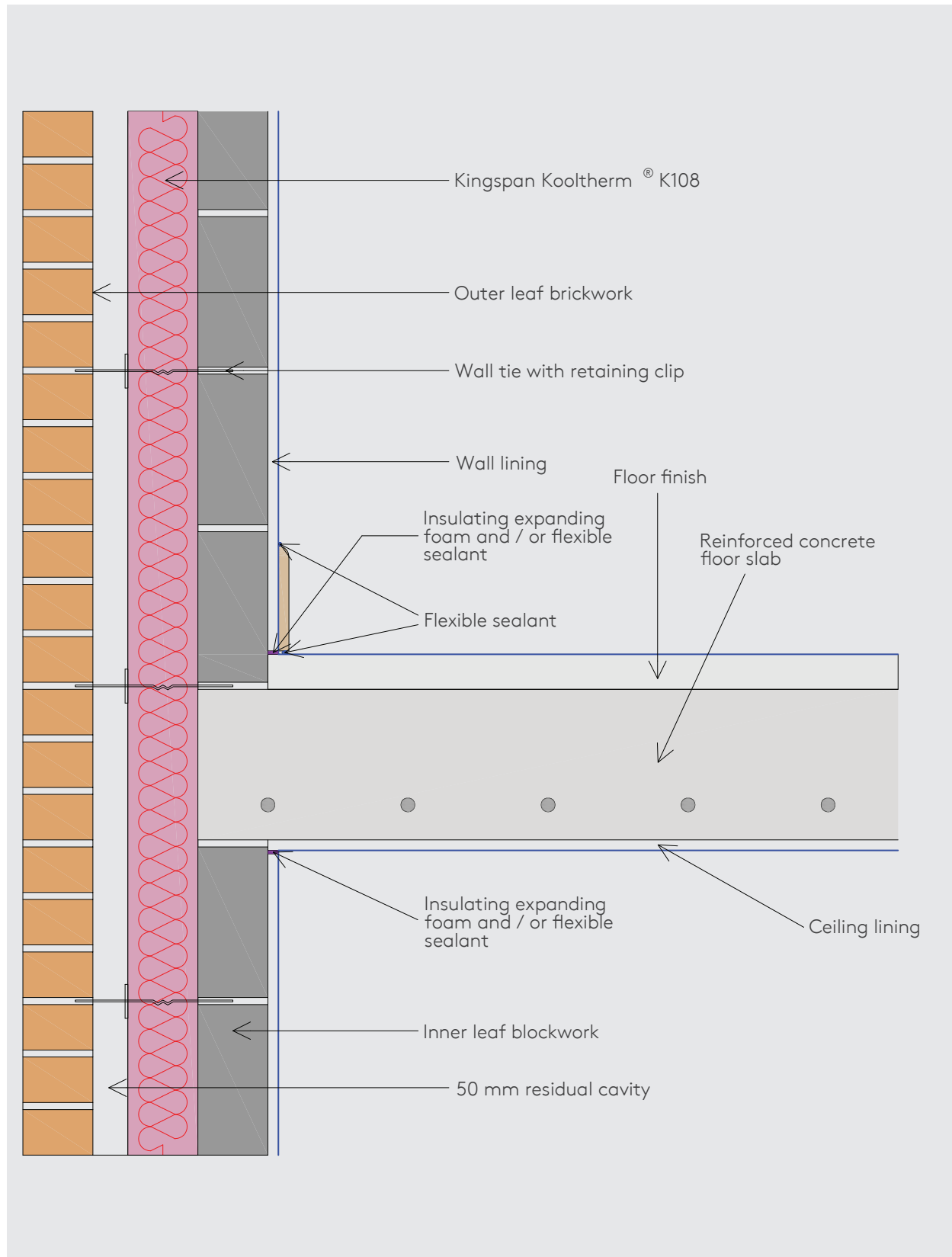

E6 - Intermediate floor (timber)

General construction specification

- Wall lining (12.5 mm plasterboard on dabs)
- Inner leaf blockwork
- 150 mm overall cavity width with 100 mm Kingspan Kooltherm® K108 Cavity Board and 50 mm cavity
- Outer leaf brickwork

Thermal performance process sequence

- Kingspan Kooltherm® K108 should be firmly held against the inner leaf of blockwork.
- Continue Kingspan Kooltherm® K108 across the intermediate floor abutment zone.
- The cavity and wall ties should be kept clean of mortar and other debris during construction.
- Ensure there are no gaps between the insulation boards
- Ensure all Kingspan Kooltherm® K108 joints are lightly butted.

Air barrier process sequence

- Seal between the wall lining and floor screed lining with flexible sealant.
- Seal between the wall lining and ceiling lining with flexible sealant.
- Apply flexible sealant between the skirting board and the floor screed / finish.
- Seal all penetrations through the air barrier using a flexible sealant or plaster mortar.

Detail

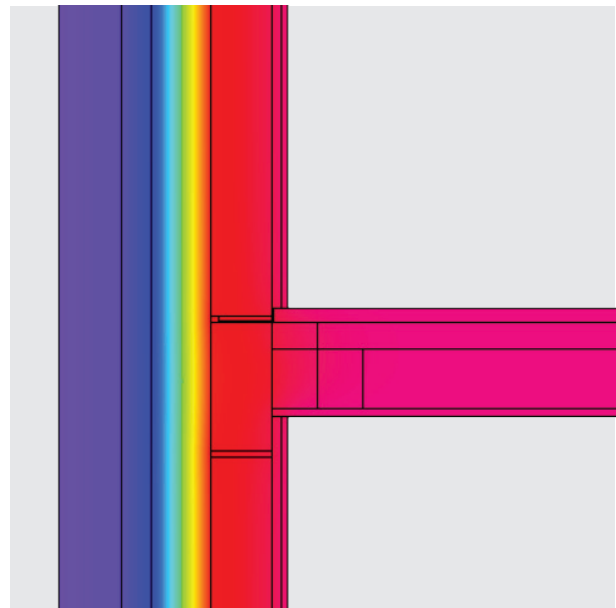
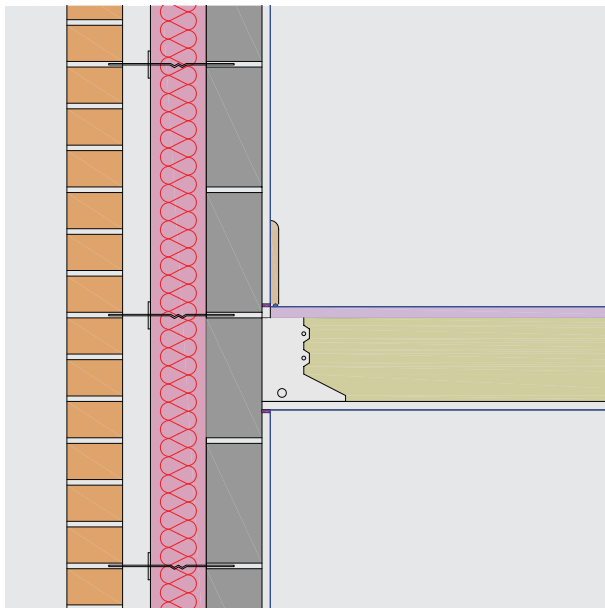

Description	Internal blockwork conductivity (W/mK)				
	0.11	0.15	0.19	0.51	1.13
U-value achieved (W/m²K)	0.14	0.15	0.15	0.16	0.16
Linear thermal transmittance Ψ (W/mK)	0.000	0.000	0.000	0.000	0.000
Temperature factor (f)	0.97	0.96	0.96	0.97	0.96

NB Calculations based on 150 mm deep timber joists partially filled with 100 mm mineral wool (0.044 W/mK). Floor finish thermal conductivity 0.15 W/mK. Joist hanger thermal conductivity 50 W/mK (steel).

E6 - Intermediate floor (timber)

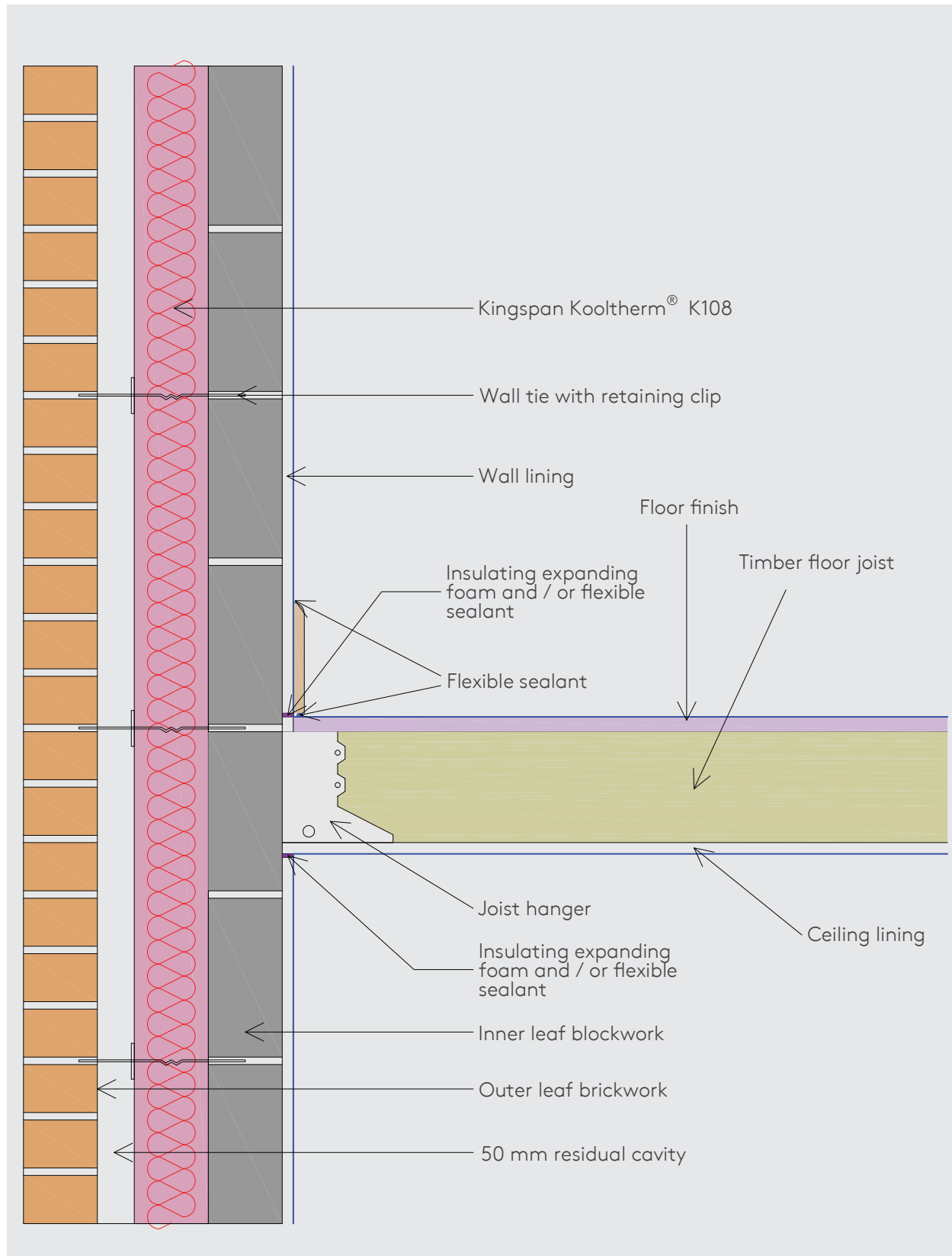

E10 - Eaves (insulation at ceiling level)

General construction specification

- Wall lining (12.5 mm plasterboard on dabs)
- Inner leaf blockwork
- 150 mm overall cavity width with 100 mm Kingspan Kooltherm® K108 Cavity Board and 50 mm cavity
- Outer leaf brickwork

Air barrier process sequence

- Seal the wall plate on a continuous layer of mortar.
- Seal the gap between the wall and ceiling linings with flexible sealant / plaster mortar.
- Seal all penetrations through the air barrier using a flexible sealant / plaster mortar.

Thermal performance process sequence

- Kingspan Kooltherm® K108 should be firmly held against the inner leaf of blockwork.
- Ensure the gap between the wall plate and eaves ventilator is completely filled with flexible insulation. The flexible insulation is to have an R-value of 1.2 m²K/W or higher.
- The flexible insulation should be tucked down the head of the cavity to enable continuity of the flexible insulation and Kingspan Kooltherm® K108 throughout the junction.
- Ensure the full depth of ceiling insulation, between and over joist ceiling insulation, abuts the eaves insulation.
- Kingspan Kooltherm® K108 and eaves insulation should be firmly held against / butted tight against the fire stop.
- The cavity and wall ties should be kept clean of mortar and other debris during construction.
- Ensure all Kingspan Kooltherm® K108 joints are lightly butted.

Detail

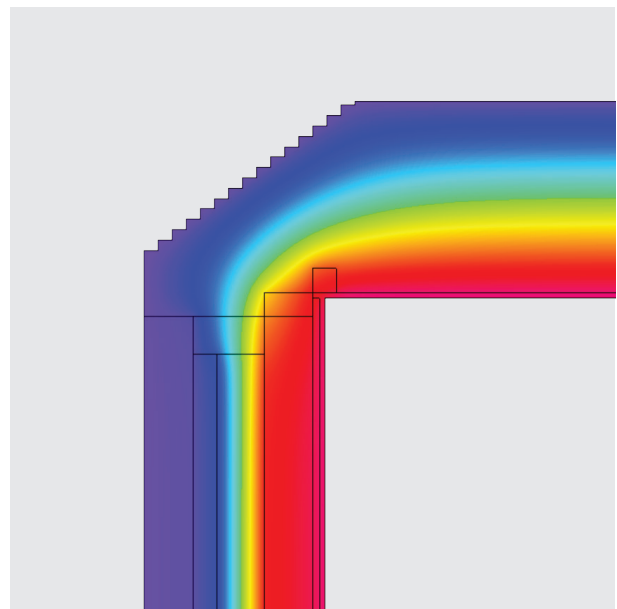
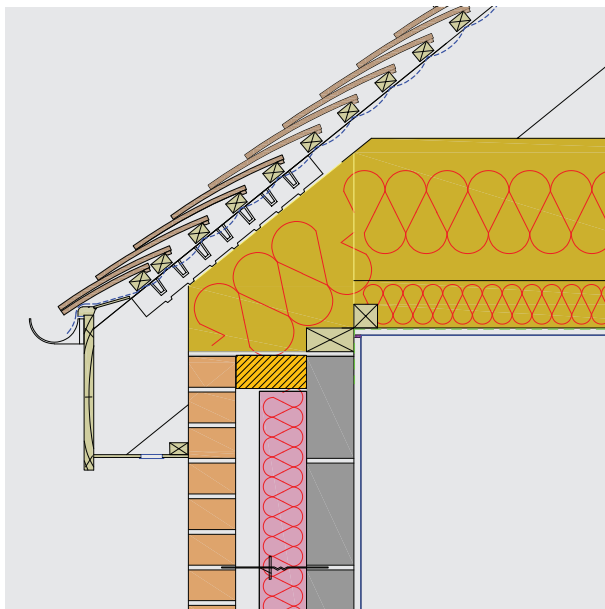

Description	Internal blockwork conductivity (W/mK)				
	0.11	0.15	0.19	0.51	1.13
U-value achieved (W/m ² K)	0.14	0.15	0.15	0.16	0.16
Linear thermal transmittance Ψ (W/mK)	0.045	0.045	0.045	0.047	0.049
Temperature factor (f)	0.94	0.94	0.94	0.94	0.95

NB Calculations based on a ceiling with 100 mm mineral wool (0.044 W/mK) between joists and 300 mm mineral wool (0.044 W/mK) above joists.

E10 - Eaves (insulation at ceiling level)

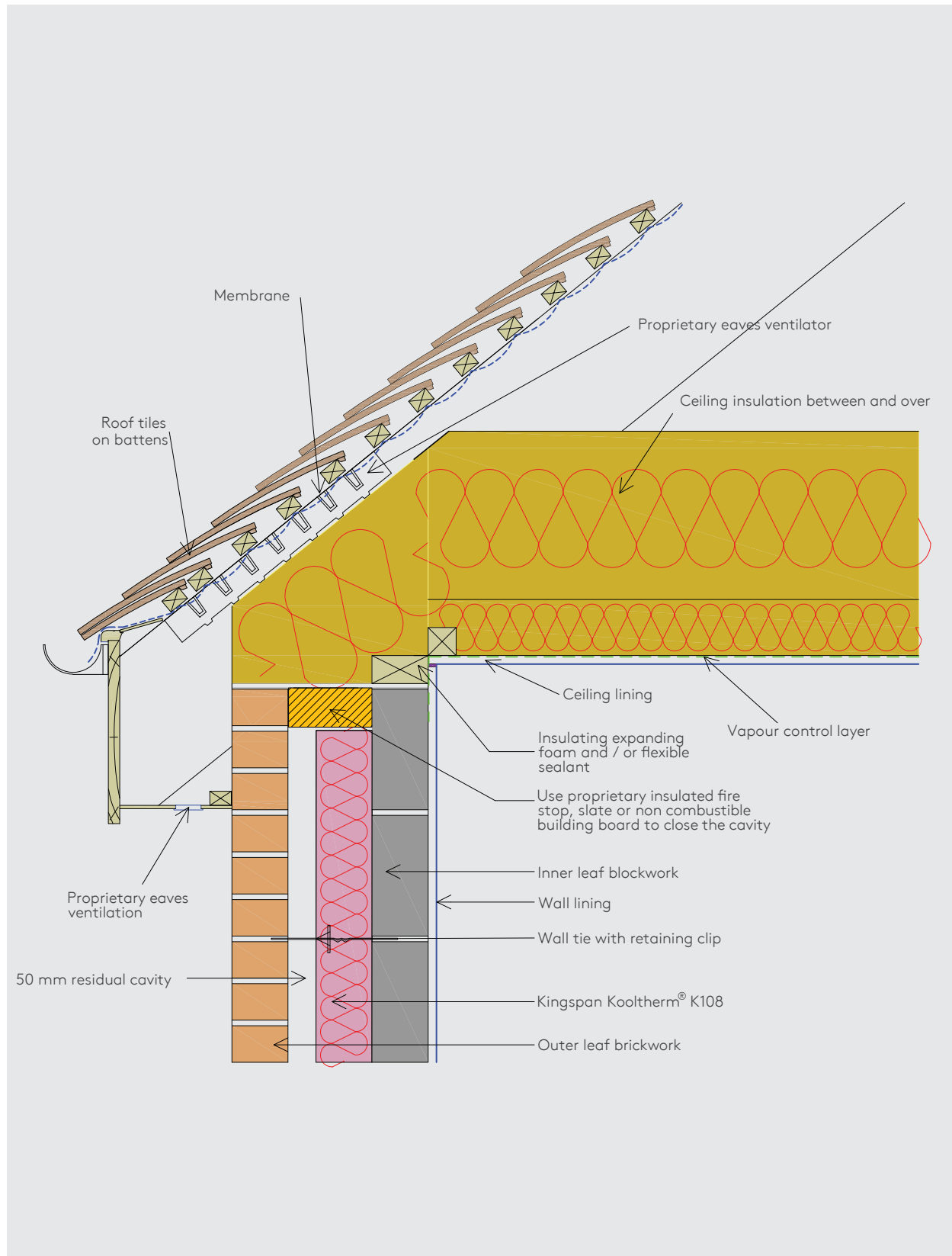

E11 - Eaves (insulation at rafter level)

General construction specification

- Wall lining (12.5 mm plasterboard on dabs)
- Inner leaf blockwork
- 150 mm overall cavity width with 100 mm Kingspan Kooltherm® K108 Cavity Board and 50 mm cavity
- Outer leaf brickwork

Air barrier process sequence

- Bed the wall plate on a continuous layer of mortar.
- Seal the gap between the wall and ceiling linings with flexible sealant / plaster mortar.
- Seal all penetrations through the air barrier using a flexible sealant / plaster mortar.

Thermal performance process sequence

- Kingspan Kooltherm® K108 should be firmly held against the inner leaf of blockwork.
- Ensure the gap between the wall plate and eaves ventilator is completely filled with flexible insulation. The flexible insulation is to have an R-value of 1.2 m²K/W or higher.
- The flexible insulation should be tucked down the head of the cavity to enable continuity of the flexible insulation and Kingspan Kooltherm® K108 throughout the junction.
- Ensure the full depth of ceiling insulation, between and over joist ceiling insulation, abuts the eaves insulation.
- Kingspan Kooltherm® K108 and eaves insulation should be firmly held against / butted tight against the fire stop.
- The cavity and wall ties should be kept clean of mortar and other debris during construction.
- Ensure all Kingspan Kooltherm® K108 joints are lightly butted.

Detail

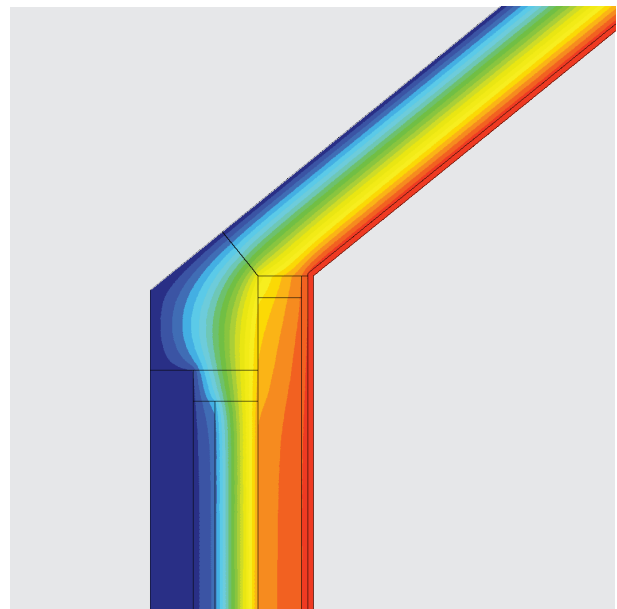
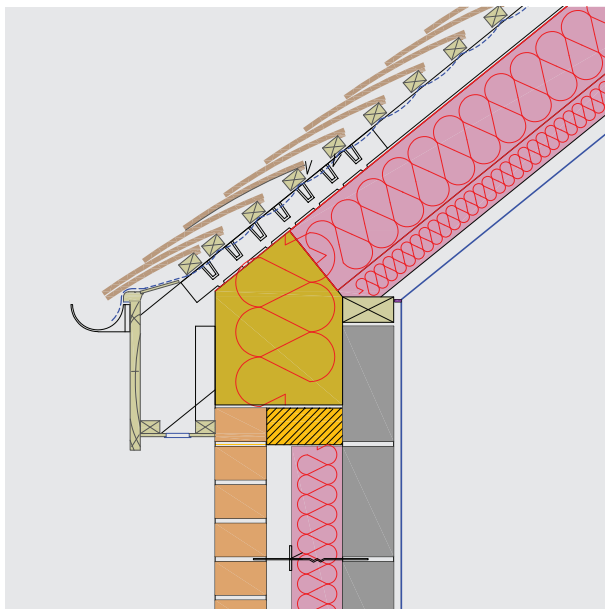

Description	Internal blockwork conductivity (W/mK)				
	0.11	0.15	0.19	0.51	1.13
U-value achieved (W/m ² K)	0.14	0.15	0.15	0.16	0.16
Linear thermal transmittance Ψ (W/mK)	0.030	0.030	0.032	0.034	0.035
Temperature factor (f)	0.97	0.97	0.97	0.97	0.97

NB Calculations based on 150 mm Kingspan Kooltherm® K107 between rafters and 62.5 mm Kingspan Kooltherm® K118 beneath rafters.

E11 - Eaves (insulation at rafter level)

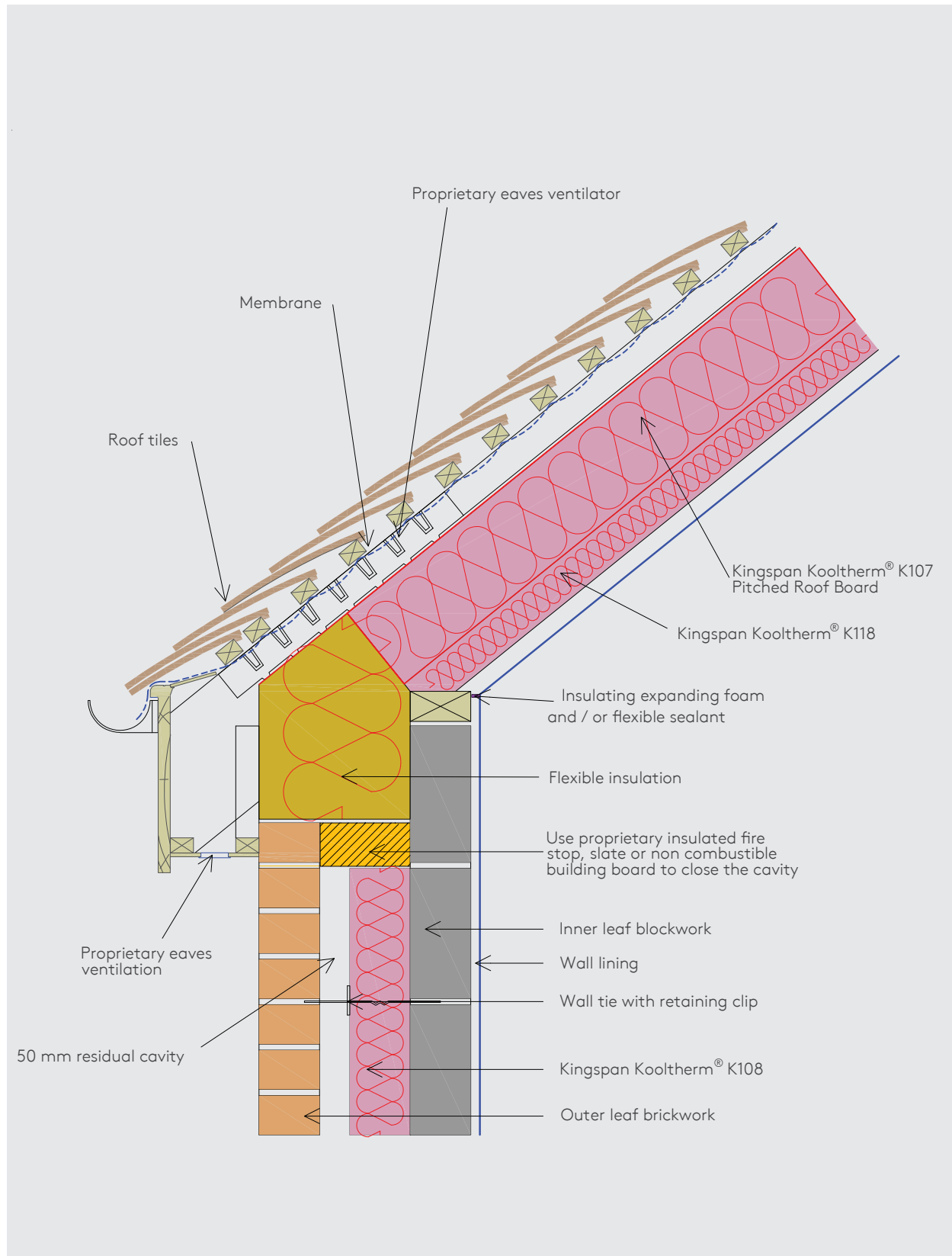

E12 - Gable (insulation at ceiling level)

General construction specification

- Wall lining (12.5 mm plasterboard on dabs)
- Inner leaf blockwork
- 150 mm overall cavity width with 100 mm Kingspan Kooltherm® K108 Cavity Board and 50 mm cavity
- Outer leaf brickwork

Air barrier process sequence

- Seal the gap between the wall and ceiling linings with flexible sealant / plaster mortar.
- Seal all penetrations through the air barrier using a flexible sealant / plaster mortar.

Thermal performance process sequence

- Kingspan Kooltherm® K108 should be firmly held against the inner leaf of blockwork.
- Pack flexible insulation between the last truss / joist and gable wall.
- Ensure the ceiling insulation over the truss / joist tightly abuts the flexible insulation packed between the last truss / joists.
- Ensure the ceiling insulation between and over the truss / joists extends to the inner edge of the wall.
- The cavity and wall ties should be kept clean of mortar and other debris during construction.
- Ensure all Kingspan Kooltherm® K108 joints are lightly butted.
- Kingspan Kooltherm® K108 is to be installed a minimum of 200 mm above the top surface of the ceiling insulation.

Detail

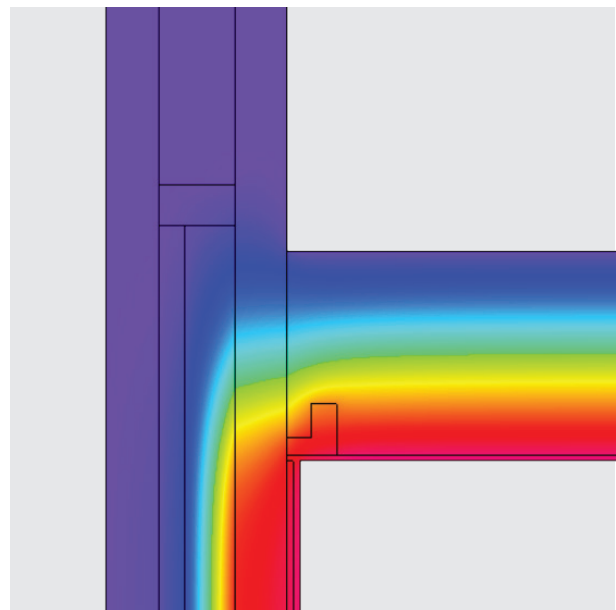
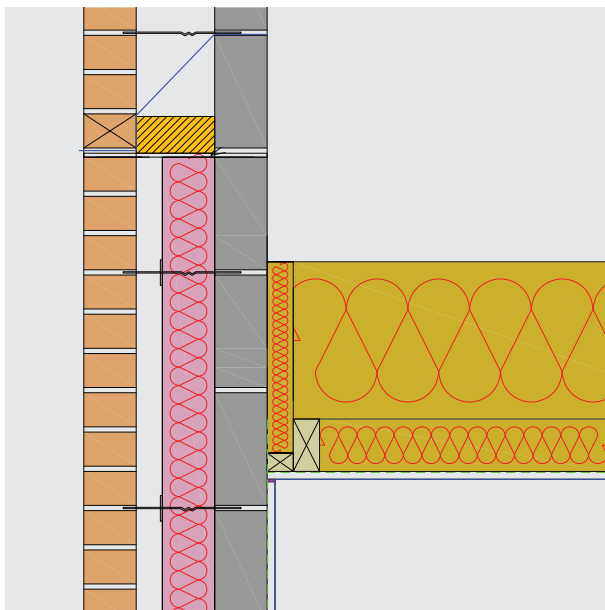

Description	Internal blockwork conductivity (W/mK)				
	0.11	0.15	0.19	0.51	1.13
U-value achieved (W/m ² K)	0.14	0.15	0.15	0.16	0.16
Linear thermal transmittance Ψ (W/mK)	0.050	0.055	0.073	0.098	0.167
Temperature factor (f)	0.93	0.92	0.92	0.90	0.88

NB Calculations based on a ceiling with 100 mm mineral wool (0.044 W/mK) between joists and 300 mm mineral wool (0.044 W/mK) above joists.

E12 - Gable (insulation at ceiling level)

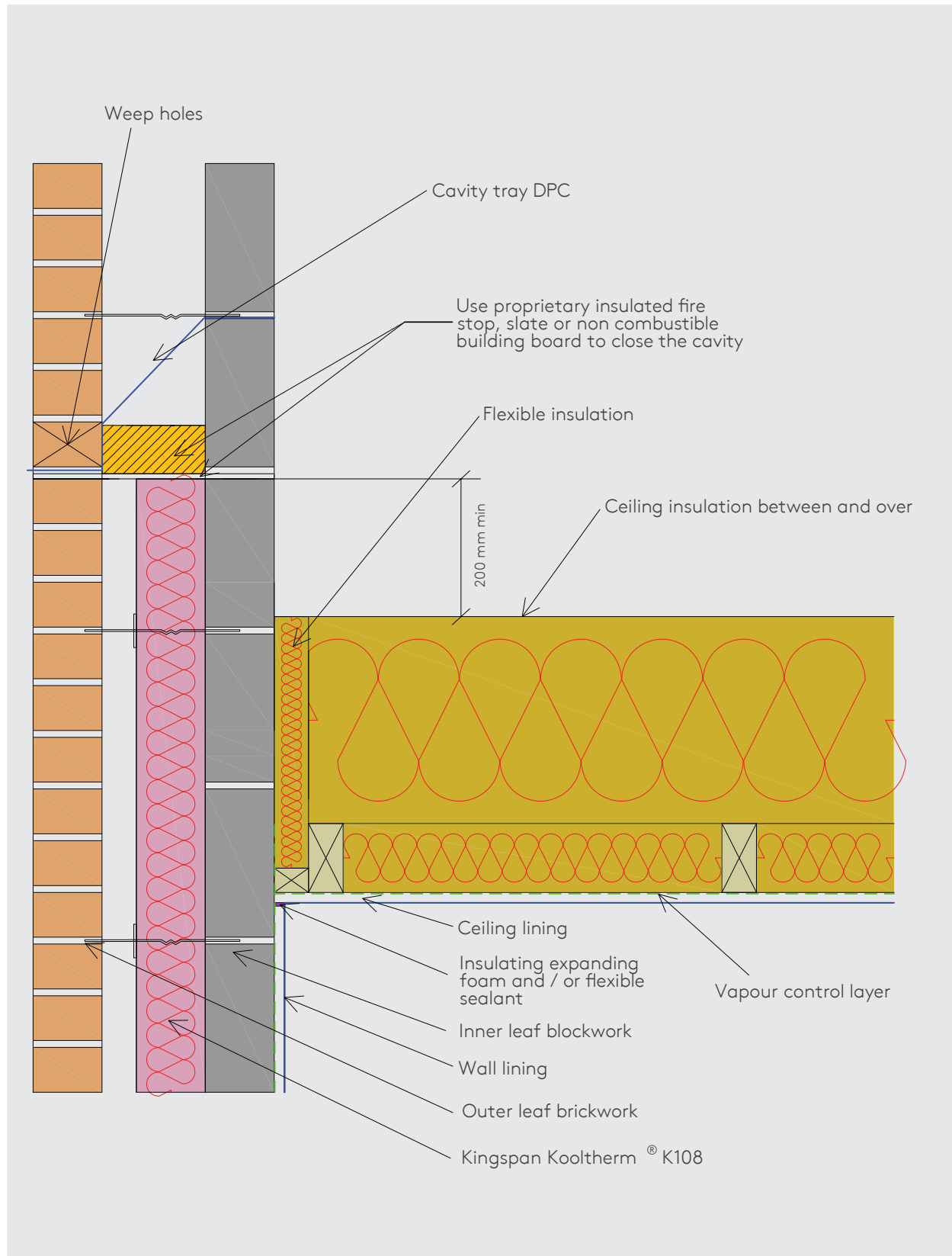

E13 - Gable (insulation at rafter level)

General construction specification

- Wall lining (12.5 mm plasterboard on dabs)
- Inner leaf blockwork
- 150 mm overall cavity width with 100 mm Kingspan Kooltherm® K108 Cavity Board and 50 mm cavity
- Outer leaf brickwork

Air barrier process sequence

- Seal the gap between the wall and ceiling linings with flexible sealant / plaster mortar.
- Seal all penetrations through the air barrier using a flexible sealant / plaster mortar.

Thermal performance process sequence

- Kingspan Kooltherm® K108 should be firmly held against the inner leaf of blockwork.
- Kingspan Kooltherm® K108 should be firmly held against the inner leaf of blockwork.
- Ensure the gap between the wall plate and eaves ventilator is completely filled with flexible insulation. The flexible insulation is to have an R-value of 1.2 m²K/W or higher.
- The flexible insulation should be tucked down the head of the cavity to enable continuity of this and Kingspan Kooltherm® K108 throughout the junction.
- Ensure the full depth of ceiling insulation, between and over joist ceiling insulation, abuts the eaves insulation.
- Kingspan Kooltherm® K108 should be firmly held against / butted tight against the fire stop.
- The cavity and wall ties should be kept clean of mortar and other debris during construction.

Detail

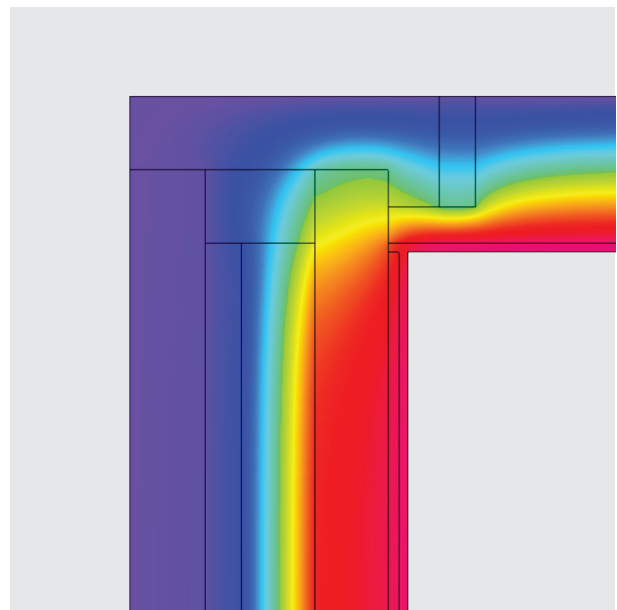
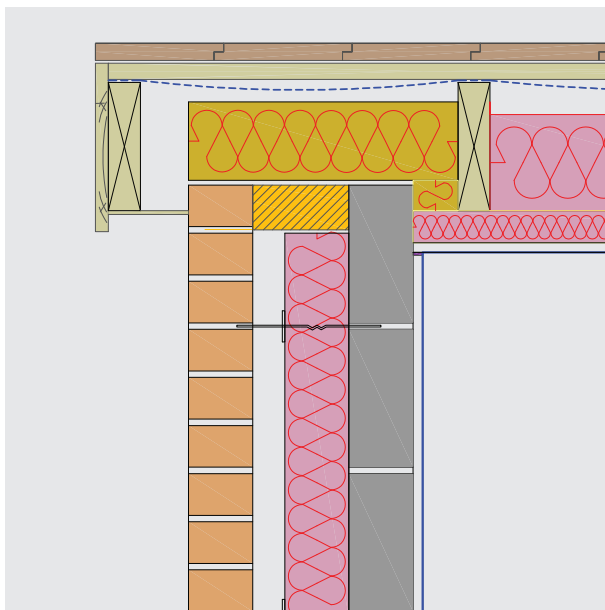

Description	Internal blockwork conductivity (W/mK)				
	0.11	0.15	0.19	0.51	1.13
U-value achieved (W/m ² K)	0.14	0.15	0.15	0.16	0.16
Linear thermal transmittance Ψ (W/mK)	0.058	0.061	0.064	0.076	0.086
Temperature factor (<i>f</i>)	0.92	0.92	0.92	0.92	0.93

NB Calculations based on 150 mm Kingspan Kooltherm® K107 Pitched Roof Board between rafters and 62.5 mm Kingspan Kooltherm® K118 Insulated Plasterboard beneath rafters.

E13 - Gable (insulation at rafter level)

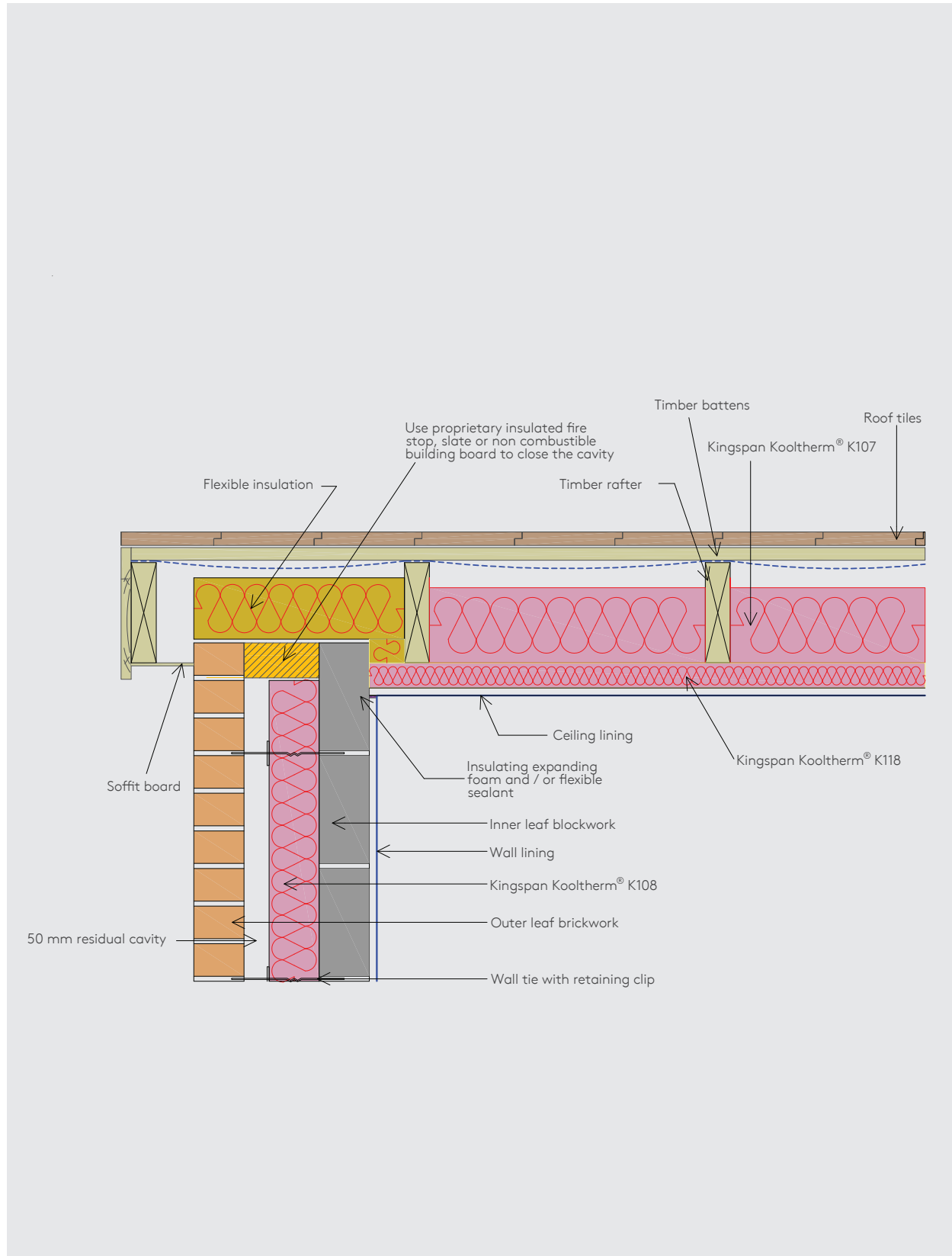

E14 - Flat roof (no parapet)

General construction specification

- Wall lining (12.5 mm plasterboard on dabs)
- Inner leaf blockwork
- 150 mm overall cavity width with 100 mm Kingspan Kooltherm® K108 Cavity Board and 50 mm cavity
- Outer leaf brickwork

Thermal performance process sequence

- Kingspan Kooltherm® K108 should be firmly held against the inner leaf of blockwork.
- Ensure Kingspan Kooltherm® K108 is taken up level with the top of the wall firmly held against / butted tight against the fire stop.
- Pack flexible insulation between the last joist / gable ladder. Fully fill the void and ensure the insulation is in contact with the roof deck and cavity closer.
- Ensure Kingspan Therमारoof® TR26 / TR27 or Kingspan Thermataper® TT46 / TT47 warm deck roof insulation extends to the edge of the roof.

- The cavity and wall ties should be kept clean of mortar and other debris during construction.
- Ensure all Kingspan Kooltherm® K108 joints are lightly butted.

Air barrier process sequence

- Seal the gap between the wall and ceiling linings with flexible sealant / plaster mortar.
- Seal all penetrations through the air barrier using a flexible sealant / plaster mortar.

Detail

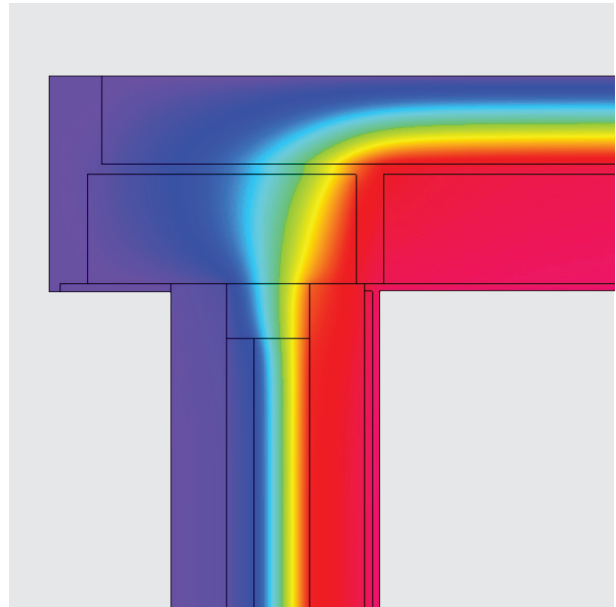
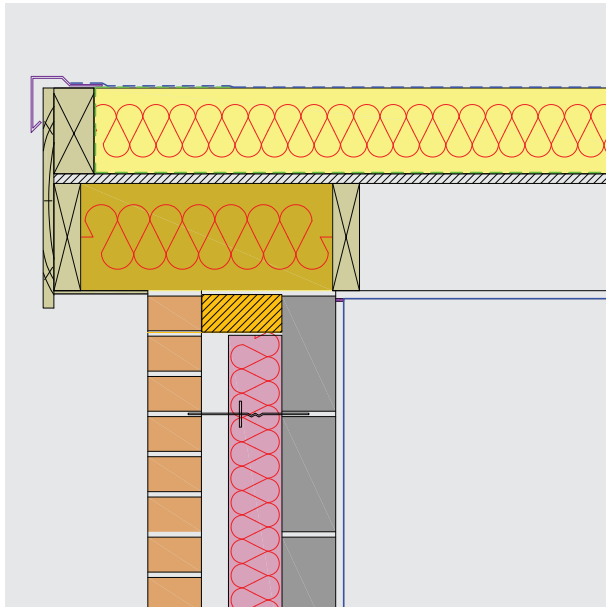

Description	Internal blockwork conductivity (W/mK)				
	0.11	0.15	0.19	0.51	1.13
U-value achieved (W/m²K)	0.14	0.15	0.15	0.16	0.16
Linear thermal transmittance Ψ (W/mK)					
Kingspan Therमारoof® TR26	0.048	0.049	0.049	0.051	0.051
Kingspan Therमारoof® TR27	0.049	0.050	0.050	0.052	0.052
Temperature factor (f)					
Kingspan Therमारoof® TR26	0.96	0.96	0.96	0.96	0.96
Kingspan Therमारoof® TR27	0.96	0.96	0.96	0.96	0.96

NB Calculations based on 160 mm Kingspan Therमारoof® TR27 / TR26 for the flat roof. If Kingspan Thermataper® TT47 / TT46 is used, a minimum thickness of 160 mm would need to be accommodated at the edge of the roof. This would allow the above Ψ -values to be used (TR27 for TT47 and TR26 for TT46).

E14 - Flat roof (no parapet)

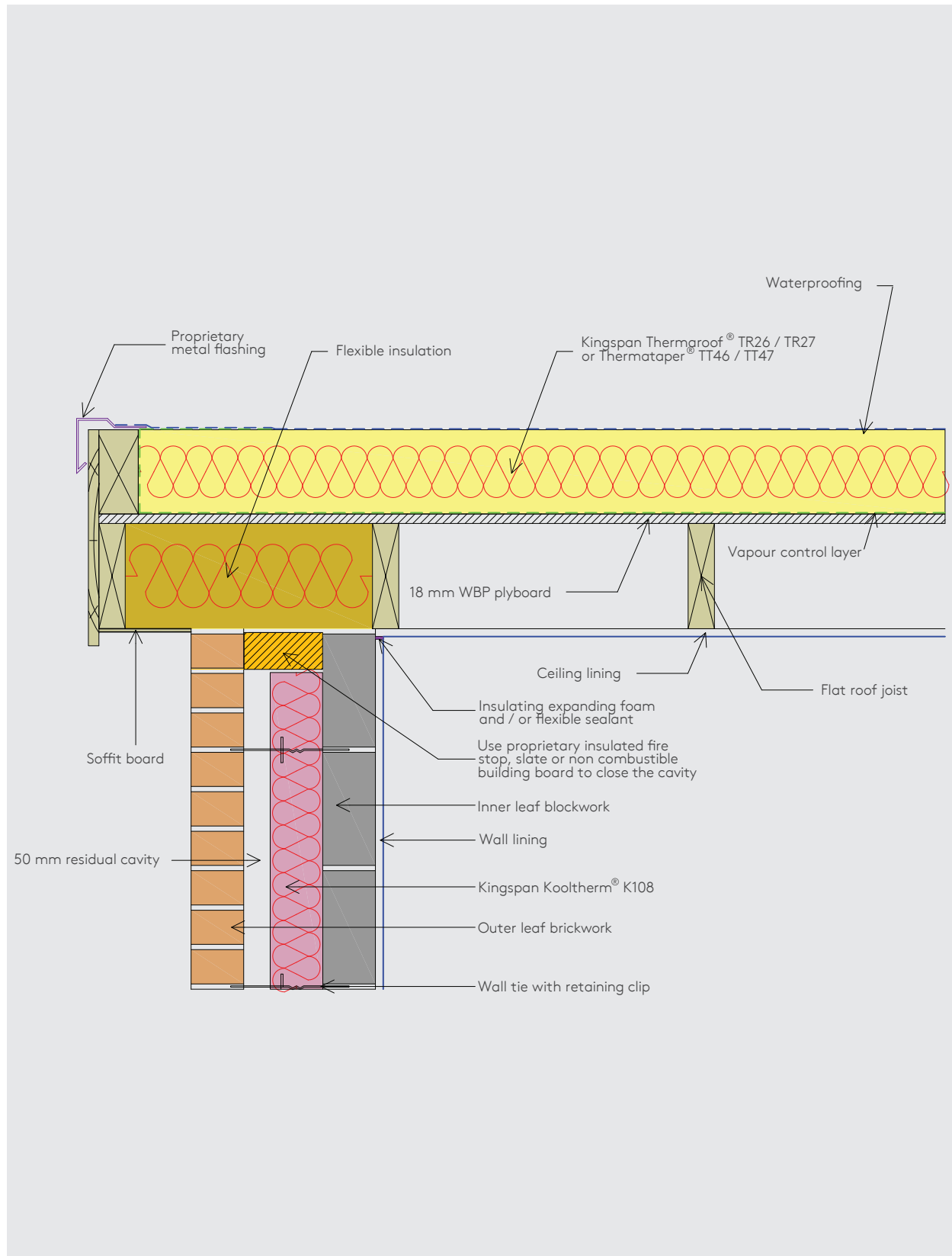

E15 - Flat roof (with parapet)

General construction specification

- Wall lining (12.5 mm plasterboard on dabs)
- Inner leaf blockwork
- 150 mm overall cavity width with 100 mm Kingspan Kooltherm® K108 Cavity Board and 50 mm cavity
- Outer leaf brickwork

- The cavity and wall ties should be kept clean of mortar and other debris during construction.
- Kingspan Kooltherm® K108 should be firmly held against / butted lightly against fire stop.

Thermal performance process sequence

- Kingspan Kooltherm® K108 should be firmly held against the inner leaf of blockwork.
- Install 25 mm (min.) Kingspan Therमारoof® TR26 / TR27 upstand insulation around the parapet.
- Ensure Kingspan Therमारoof® TR26 / TR27 roof or upstand insulation tightly abuts the inner face of the parapet blockwork.
- Ensure there is a distance of at least 300 mm (min.) between the top of the Kingspan Therमारoof® TR26 / TR27 upstand insulation and the bottom of the Kingspan Therमारoof® TR26 / TR27 or Kingspan Thermataper® TT46 / TT47 roof insulation.

Air barrier process sequence

- Seal the gap between the wall and ceiling linings with flexible sealant / plaster mortar.
- Seal all penetrations through the air barrier using a flexible sealant / plaster mortar.

Detail

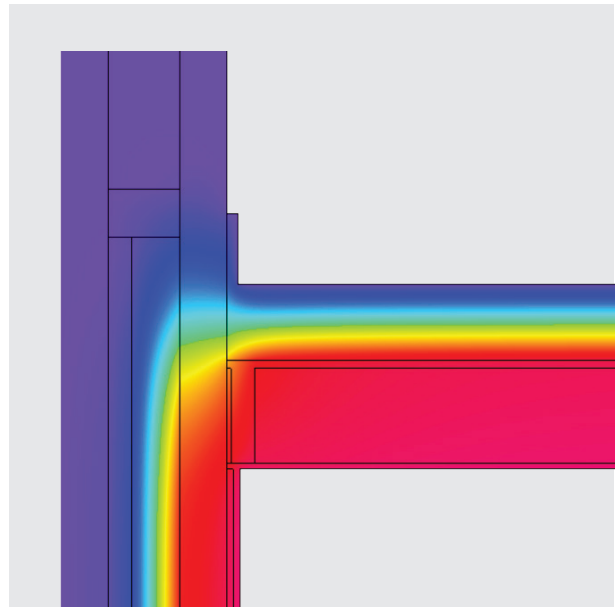
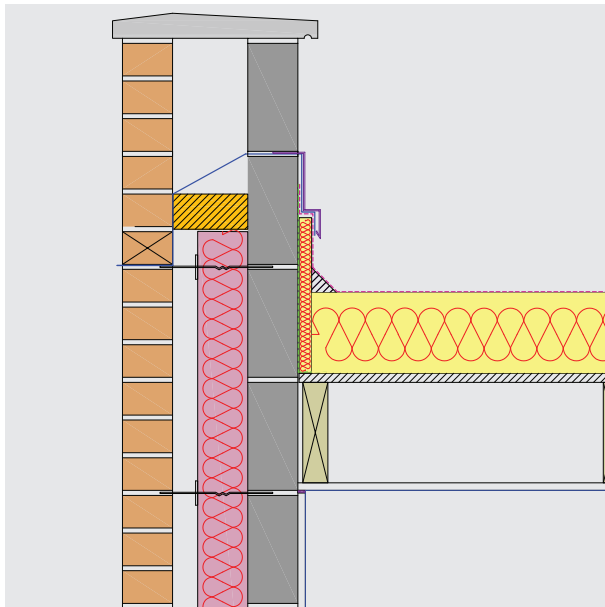

Description	Internal blockwork conductivity (W/mK)				
	0.11	0.15	0.19	0.51	1.13
U-value achieved (W/m ² K)	0.14	0.15	0.15	0.16	0.16
Linear thermal transmittance Ψ (W/mK)					
Kingspan Therमारoof® TR26	0.071	0.077	0.084	0.123	0.196
Kingspan Therमारoof® TR27	0.071	0.078	0.084	0.124	0.197
Temperature factor (f)					
Kingspan Therमारoof® TR26	0.95	0.95	0.94	0.93	0.90
Kingspan Therमारoof® TR27	0.95	0.95	0.94	0.93	0.90

NB Calculations based on 160 mm Kingspan Therमारoof® TR27 / TR26 for the flat roof. If Kingspan Thermataper® TT47 / TT46 is used, a minimum thickness of 160 mm would need to be accommodated at the edge of the roof. This would allow the above Psi values to be used (TR27 for TT47 and TR26 for TT46).

E15 - Flat roof (with parapet)

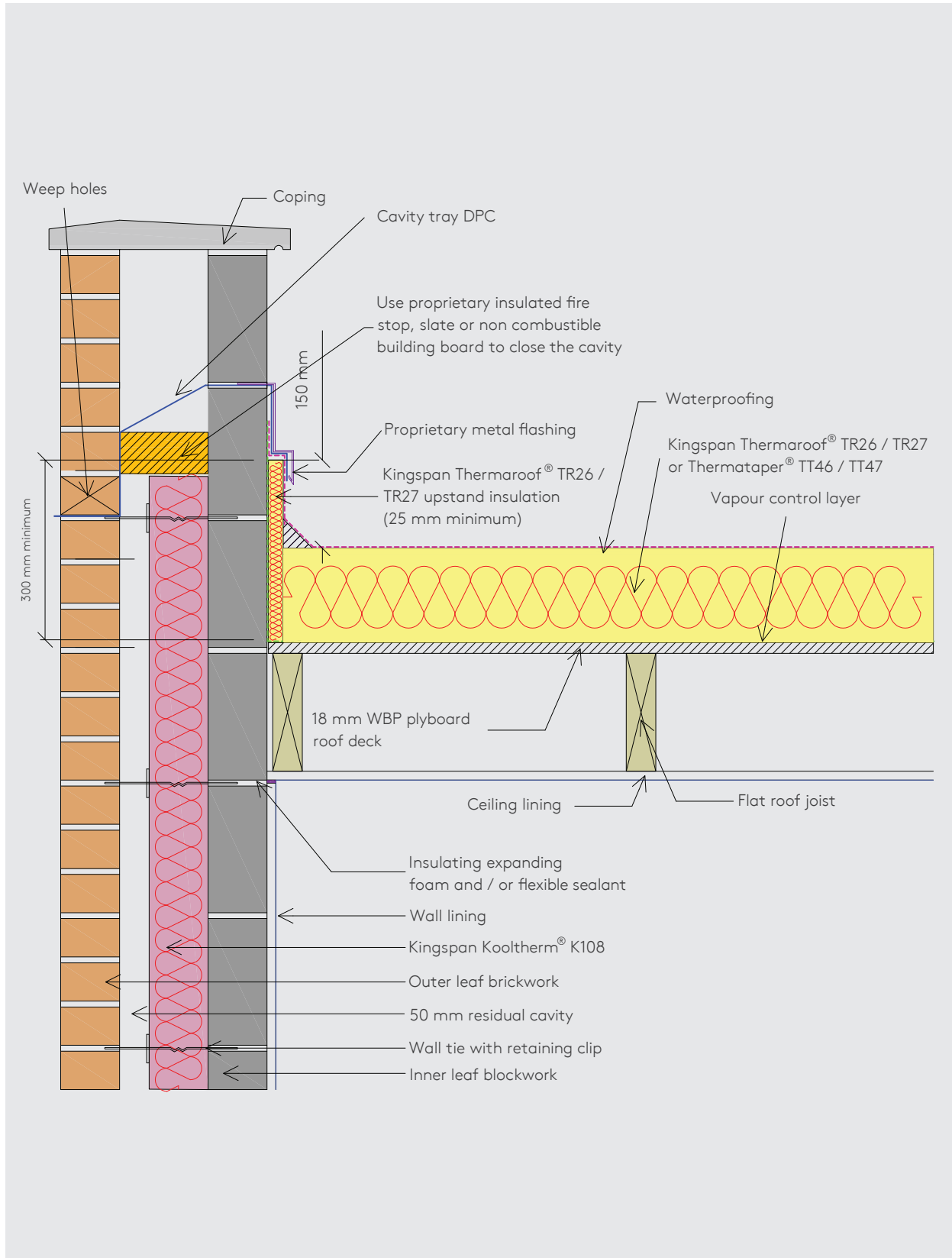

E16 - Corner

General construction specification

- Wall lining (12.5 mm plasterboard on dabs)
- Inner leaf blockwork
- 150 mm overall cavity width with 100 mm Kingspan Kooltherm® K108 Cavity Board and 50 mm cavity
- Outer leaf brickwork

Air barrier process sequence

- Seal the gap between the wall and ceiling linings with flexible sealant / plaster mortar.
- Seal all penetrations through the air barrier using a flexible sealant / plaster mortar.

Thermal performance process sequence

- Kingspan Kooltherm® K108 joints should be staggered at the building corners.
- Ensure all Kingspan Kooltherm® K108 joints are lightly butted.
- Kingspan Kooltherm® K108 should be firmly held against the inner leaf of blockwork.
- The cavity and wall ties should be kept clean of mortar and other debris during construction.

Detail

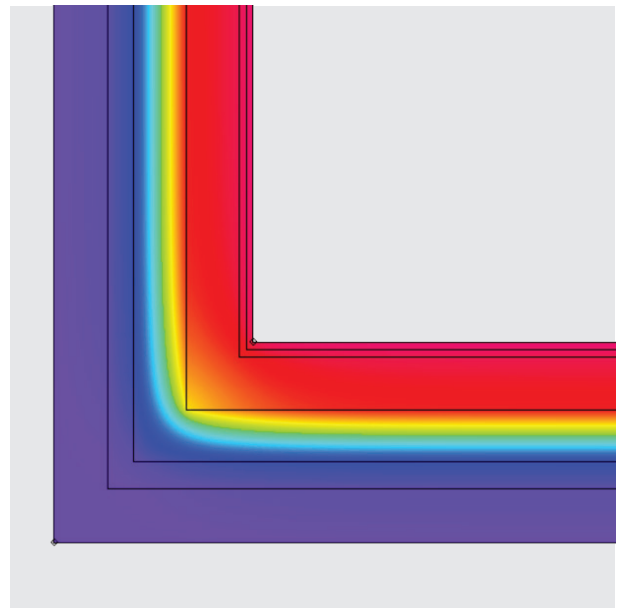
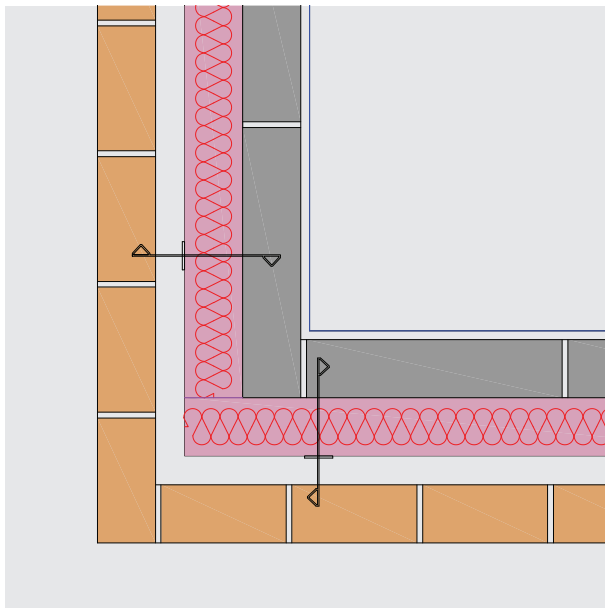

Description	Internal blockwork conductivity (W/mK)				
	0.11	0.15	0.19	0.51	1.13
U-value achieved (W/m²K)	0.14	0.15	0.15	0.16	0.16
Linear thermal transmittance Ψ (W/mK)	0.032	0.034	0.035	0.038	0.040
Temperature factor (f)	0.92	0.92	0.92	0.93	0.94

E16 - Corner

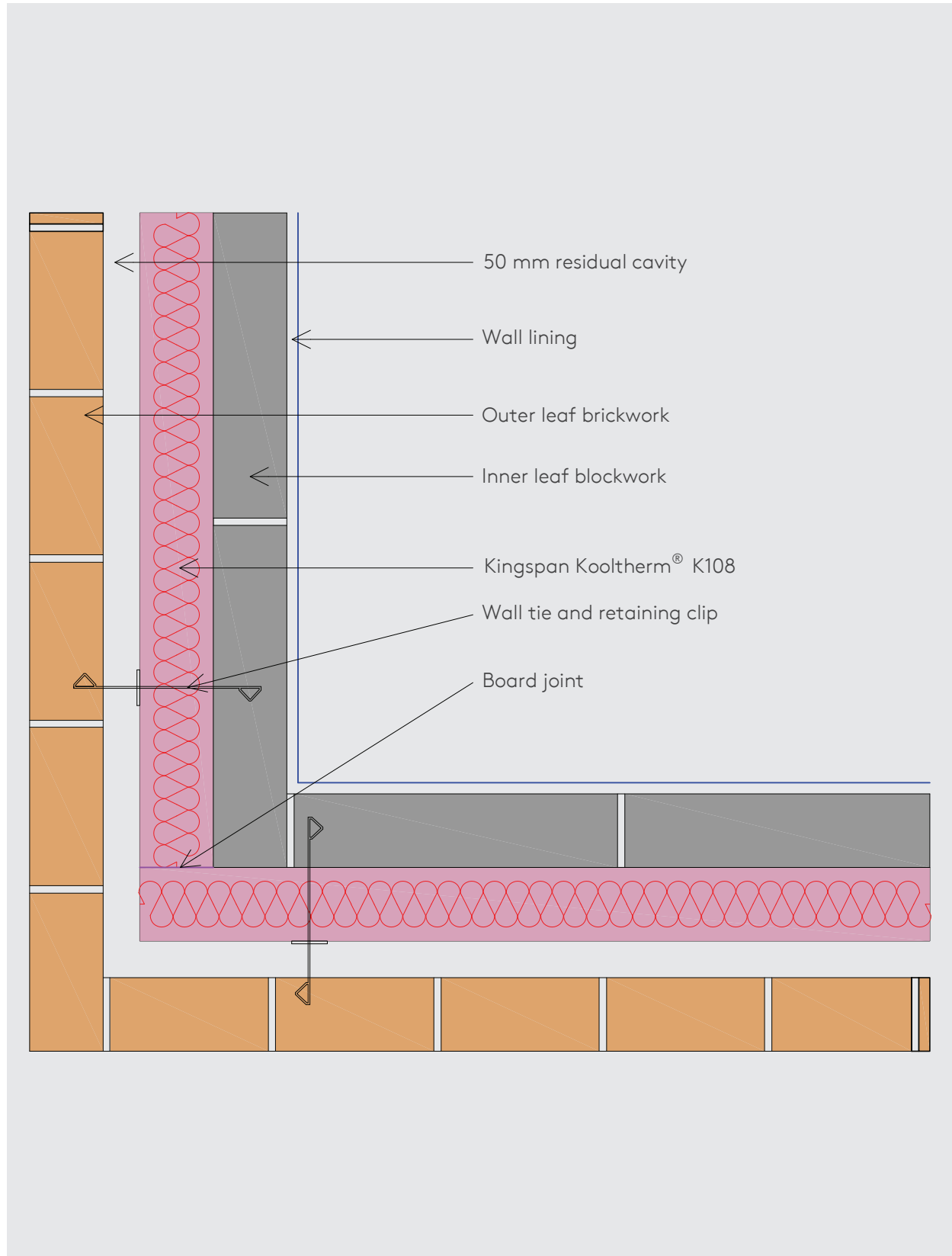

E17 - Inverted corner

General construction specification

- Wall lining (12.5 mm plasterboard on dabs)
- Inner leaf blockwork
- 150 mm overall cavity width with 100 mm Kingspan Kooltherm® K108 Cavity Board and 50 mm cavity
- Outer leaf brickwork

Air barrier process sequence

- Seal the gap between the wall and ceiling linings with flexible sealant / plaster mortar.
- Seal all penetrations through the air barrier using a flexible sealant / plaster mortar.

Thermal performance process sequence

- Kingspan Kooltherm® K108 joints should be staggered at the building corners.
- Ensure all Kingspan Kooltherm® K108 joints are lightly butted.
- Kingspan Kooltherm® K108 should be firmly held against the inner leaf of blockwork.
- The cavity and wall ties should be kept clean of mortar and other debris during construction.

Detail

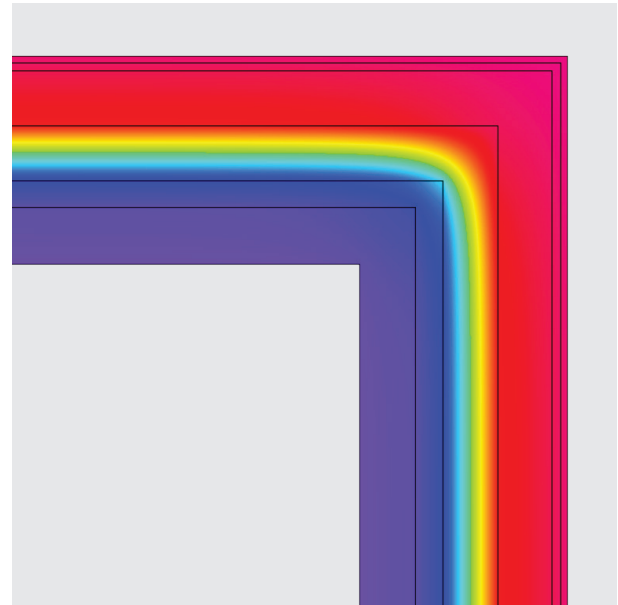
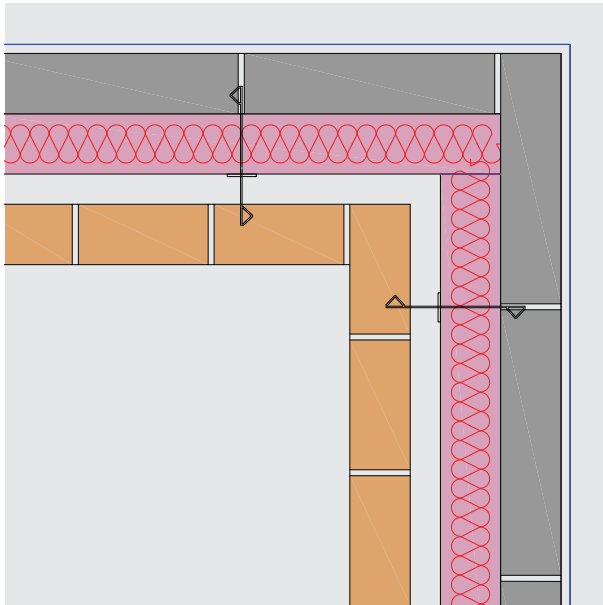

Description	Internal blockwork conductivity (W/mK)				
	0.11	0.15	0.19	0.51	1.13
U-value achieved (W/m²K)	0.14	0.15	0.15	0.16	0.16
Linear thermal transmittance Ψ (W/mK)	-0.062	-0.063	-0.064	-0.066	-0.068
Temperature factor (f)	0.98	0.98	0.98	0.98	0.98

E17 - Inverted corner

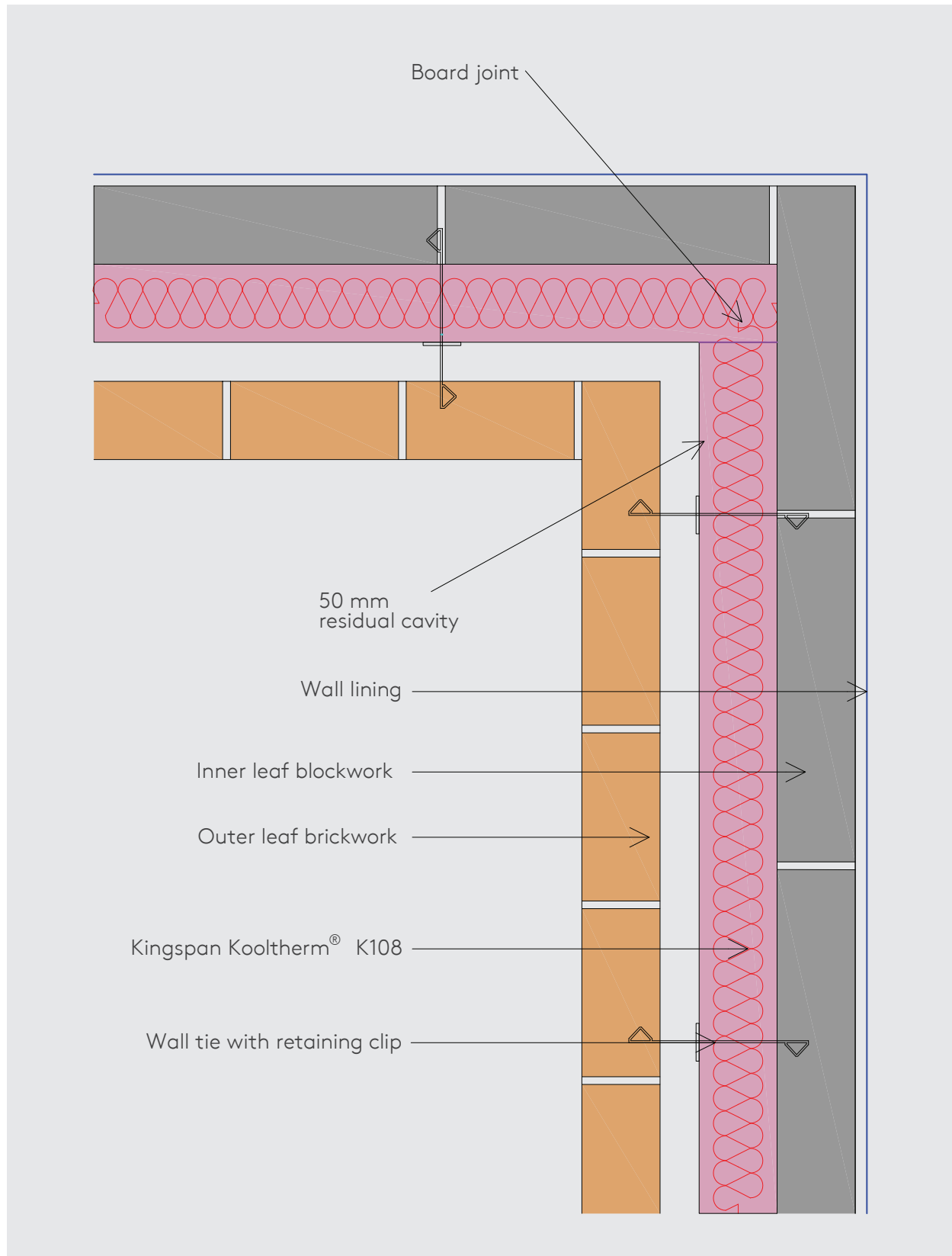

E18 - Party wall between dwellings (filled cavity)

General construction specification

- Wall lining (12.5 mm plasterboard on dabs)
- Inner leaf blockwork
- 150 mm overall cavity width with 100 mm Kingspan Kooltherm® K108 Cavity Board and 50 mm cavity
- Outer leaf brickwork

Air barrier process sequence

- Seal the gap between the wall and ceiling linings with flexible sealant / plaster mortar.
- Seal all penetrations through the air barrier using a flexible sealant / plaster mortar.

Thermal performance process sequence

- Kingspan Kooltherm® K108 joints should be staggered at the building corners.
- Ensure all Kingspan Kooltherm® K108 joints are lightly butted.
- Kingspan Kooltherm® K108 should be firmly held against the inner leaf of blockwork.
- The cavity and wall ties should be kept clean of mortar and other debris during construction.

Detail

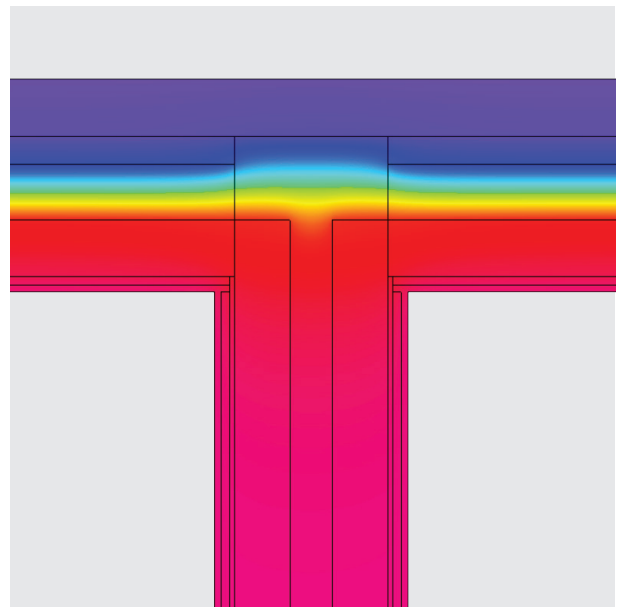
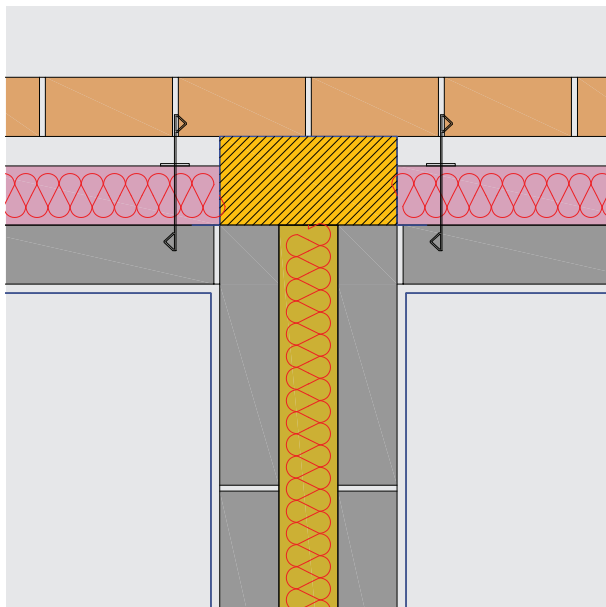

Description	Internal blockwork conductivity (W/mK)				
	0.11	0.15	0.19	0.51	1.13
U-value achieved (W/m ² K)	0.14	0.15	0.15	0.16	0.16
Linear thermal transmittance Ψ (W/mK)	0.037	0.037	0.037	0.038	0.038
Temperature factor (f)	0.96	0.96	0.96	0.96	0.97

NB Ψ -value applies for each dwelling. Ensure cavity wall qualifies for U=0.0. Cavity must have effective sealing to the top, bottom and vertical edge to prevent air movement. Cavity must be fully filled. Calculations based on mineral wool (0.044 W/mK) to fully fill the party wall cavity. Party wall blockwork thermal conductivity taken as 0.51 W/mK.

E18 - Party wall between dwellings (filled cavity)

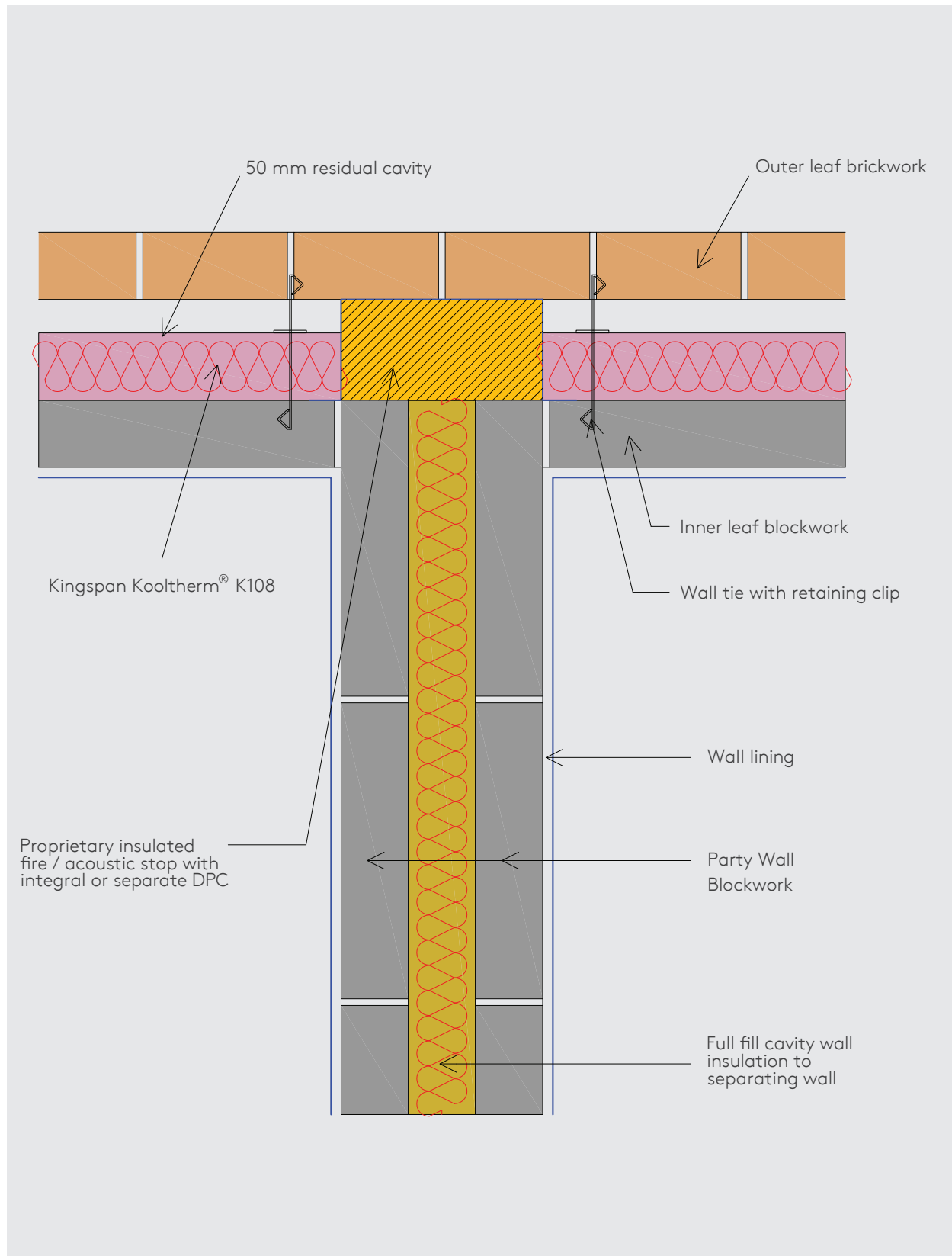

E18 - Party wall between dwellings (unfilled cavity)

General construction specification

- Wall lining (12.5 mm plasterboard on dabs)
- Inner leaf blockwork
- 150 mm overall cavity width with 100 mm Kingspan Kooltherm® K108 Cavity Board and 50 mm cavity
- Outer leaf brickwork

Air barrier process sequence

- Seal the gap between the wall and ceiling linings with flexible sealant / plaster mortar.
- Seal all penetrations through the air barrier using a flexible sealant / plaster mortar.

Thermal performance process sequence

- Kingspan Kooltherm® K108 joints should be staggered at the building corners.
- Ensure all Kingspan Kooltherm® K108 joints are lightly butted.
- Kingspan Kooltherm® K108 should be firmly held against the inner leaf of blockwork.
- The cavity and wall ties should be kept clean of mortar and other debris during construction.

Detail

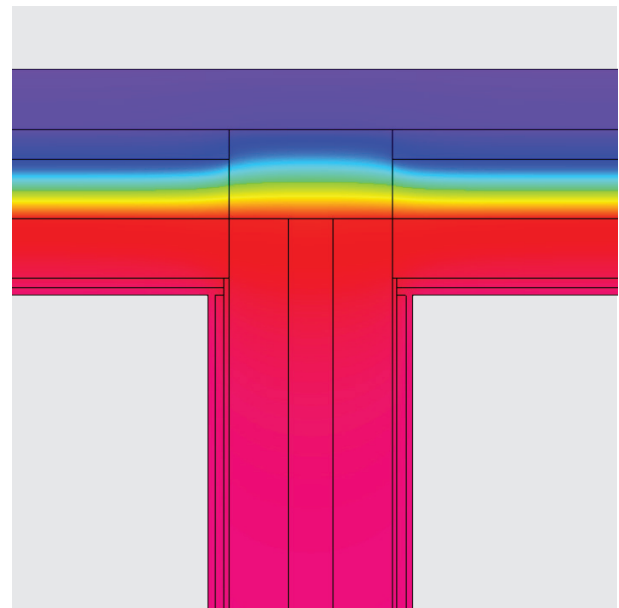
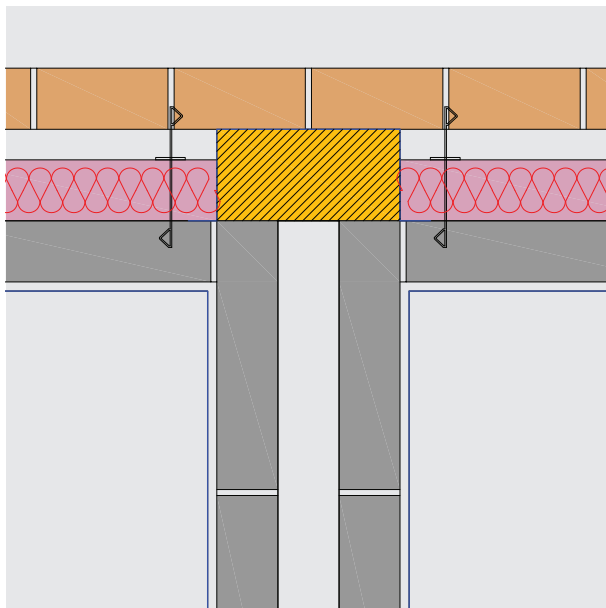

Description	Internal blockwork conductivity (W/mK)				
	0.11	0.15	0.19	0.51	1.13
U-value achieved (W/m ² K)	0.14	0.15	0.15	0.16	0.16
Linear thermal transmittance Ψ (W/mK)	0.038	0.038	0.039	0.039	0.039
Temperature factor (f)	0.96	0.96	0.96	0.96	0.96

NB Ψ -value applies for each dwelling. Ensure cavity wall qualifies for U=0.2. Cavity must have effective sealing to the top, bottom and vertical edge to prevent air movement. Party wall blockwork thermal conductivity taken as 0.51 W/mK.

E18 - Party wall between dwellings (unfilled cavity)

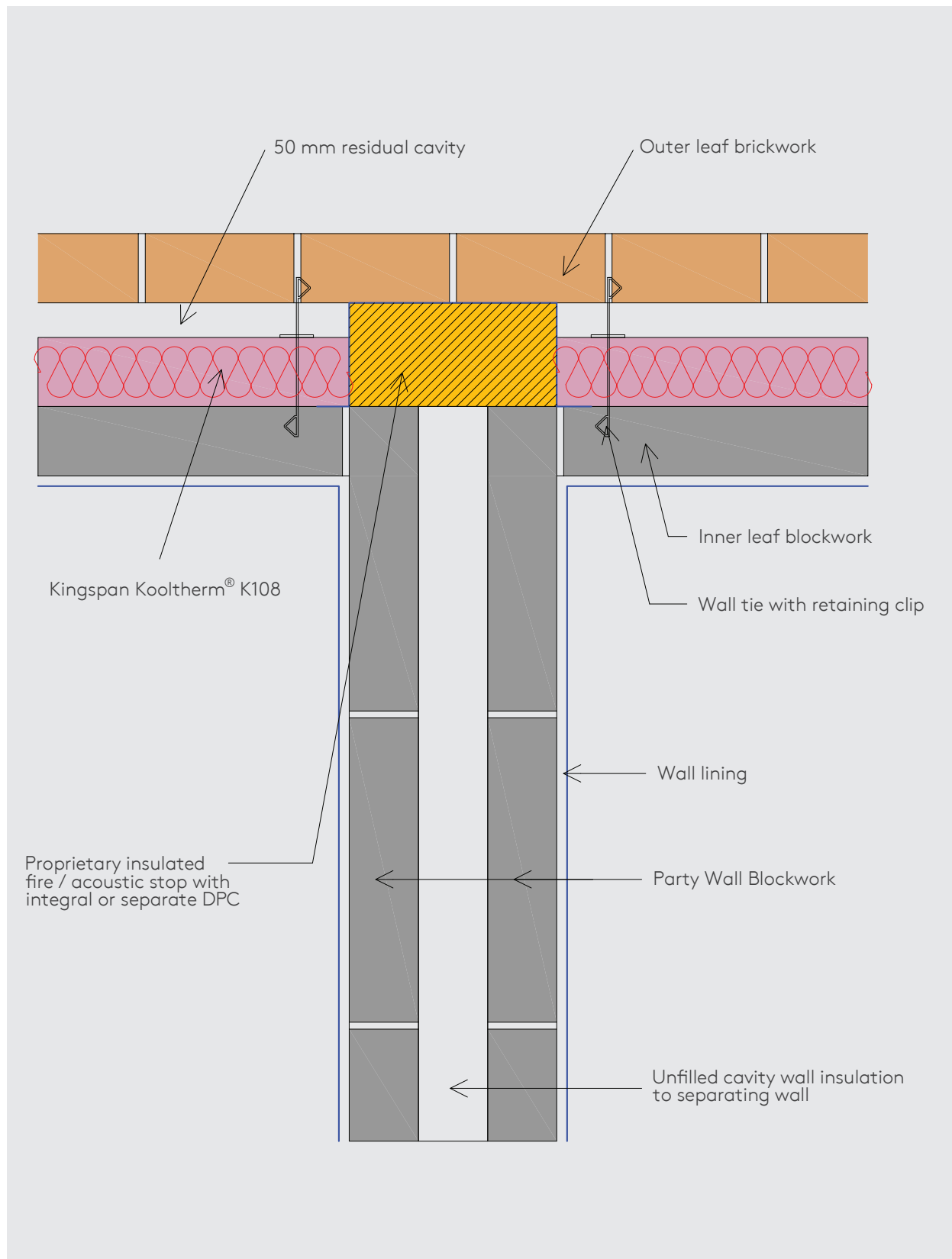

Appendix A: Summary of linear thermal transmittance Ψ (W/mk) results

External wall details		Internal blockwork conductivity (W/mK)				
		0.11	0.15	0.19	0.51	1.13
E1	Open back lintel (insulated) with perforated steel base plate	0.341	0.350	0.357	0.390	0.420
	Open back lintel (insulated) with perforated steel base plate with insulated reveal	0.253	0.267	0.277	0.320	0.357
E3	Window sills – insulated reveal	0.006	0.006	0.006	0.005	0.005
	Window sills – un-insulated reveal	0.021	0.021	0.021	0.020	0.020
E4	Window jambs – insulated reveal	0.011	0.010	0.010	0.010	0.009
	Window jambs – un-insulated reveal	0.022	0.022	0.022	0.021	0.021
E5	Ground floor – solid concrete slab	0.047	0.054	0.060	0.098	0.162
	Ground floor – beam and block (parallel)	0.054	0.060	0.069	0.112	0.179
	Ground floor – beam and block (perpendicular)	0.053	0.060	0.066	0.109	0.180
	Ground floor – suspended timber floor	0.060	0.067	0.073	0.113	0.185
E6	Intermediate floor (concrete)	0.007	0.006	0.005	0.004	0.003
E6	Intermediate floor (timber)	0.000	0.000	0.000	0.000	0.000
E10	Eaves (insulation at ceiling level)	0.045	0.045	0.045	0.047	0.049
E11	Eaves (insulation at rafter level)	0.030	0.030	0.032	0.034	0.035
E12	Gable (insulation at ceiling level)	0.050	0.055	0.073	0.098	0.167
E13	Gable (insulation at rafter level)	0.058	0.061	0.064	0.076	0.086
E14	Flat roof (Kingspan Thermarroof® TR26)	0.048	0.049	0.049	0.051	0.051
	Flat roof (Kingspan Thermarroof® TR27)	0.049	0.050	0.050	0.052	0.052
E15	Flat roof with parapet (Kingspan Thermarroof® TR26)	0.071	0.077	0.084	0.123	0.196
	Flat roof with parapet (Kingspan Thermarroof® TR27)	0.071	0.078	0.084	0.124	0.197
E16	Corner (normal)	0.032	0.034	0.035	0.038	0.040
E17	Corner (inverted)	-0.062	-0.063	-0.064	-0.066	-0.068
E18	Party wall between dwellings - filled cavity	0.037	0.037	0.037	0.038	0.038
	Party wall between dwellings - un-filled cavity	0.038	0.038	0.039	0.039	0.039

Appendix B: SAP evidence sheets

The evidentiary requirements of an energy assessment are a key part of the process. These documents provide proof that what was constructed matches what was specified and enables assessors to supply information for audit purposes to their accreditation body if required. Please tick (✓) the following columns for the details used on your project and then sign the declaration below.

External wall details		General construction sequence followed (✓)	Thermal process sequence followed (✓)	Air barrier process sequence followed (✓)	Comments
E1	Open back lintel (insulated) with perforated steel base plate	<input type="checkbox"/>	<input type="checkbox"/>	<input type="checkbox"/>	
	Open back lintel (insulated) with perforated steel base plate with insulated reveal	<input type="checkbox"/>	<input type="checkbox"/>	<input type="checkbox"/>	
E3	Window sills – insulated reveal	<input type="checkbox"/>	<input type="checkbox"/>	<input type="checkbox"/>	
	Window sills – un-insulated reveal	<input type="checkbox"/>	<input type="checkbox"/>	<input type="checkbox"/>	
E4	Window jambs – insulated reveal	<input type="checkbox"/>	<input type="checkbox"/>	<input type="checkbox"/>	
	Window jambs – un-insulated reveal	<input type="checkbox"/>	<input type="checkbox"/>	<input type="checkbox"/>	
E5	Ground floor – solid concrete slab	<input type="checkbox"/>	<input type="checkbox"/>	<input type="checkbox"/>	
	Ground floor – beam and block (parallel)	<input type="checkbox"/>	<input type="checkbox"/>	<input type="checkbox"/>	
	Ground floor – beam and block (perpendicular)	<input type="checkbox"/>	<input type="checkbox"/>	<input type="checkbox"/>	
	Ground floor – suspended timber floor	<input type="checkbox"/>	<input type="checkbox"/>	<input type="checkbox"/>	
E6	Intermediate floor (concrete)	<input type="checkbox"/>	<input type="checkbox"/>	<input type="checkbox"/>	
E6	Intermediate floor (timber)	<input type="checkbox"/>	<input type="checkbox"/>	<input type="checkbox"/>	
E10	Eaves (insulation at ceiling level)	<input type="checkbox"/>	<input type="checkbox"/>	<input type="checkbox"/>	
E11	Eaves (insulation at rafter level)	<input type="checkbox"/>	<input type="checkbox"/>	<input type="checkbox"/>	
E12	Gable (insulation at ceiling level)	<input type="checkbox"/>	<input type="checkbox"/>	<input type="checkbox"/>	
E13	Gable (insulation at rafter level)	<input type="checkbox"/>	<input type="checkbox"/>	<input type="checkbox"/>	
E14	Flat roof (Kingspan Thermarroof® TR26)	<input type="checkbox"/>	<input type="checkbox"/>	<input type="checkbox"/>	
	Flat roof (Kingspan Thermarroof® TR27)	<input type="checkbox"/>	<input type="checkbox"/>	<input type="checkbox"/>	
E15	Flat roof with parapet (Kingspan Thermarroof® TR26)	<input type="checkbox"/>	<input type="checkbox"/>	<input type="checkbox"/>	
	Flat roof with parapet (Kingspan Thermarroof® TR27)	<input type="checkbox"/>	<input type="checkbox"/>	<input type="checkbox"/>	
E16	Corner (normal)	<input type="checkbox"/>	<input type="checkbox"/>	<input type="checkbox"/>	
E17	Corner (inverted)	<input type="checkbox"/>	<input type="checkbox"/>	<input type="checkbox"/>	
E18	Party wall between dwellings - filled cavity	<input type="checkbox"/>	<input type="checkbox"/>	<input type="checkbox"/>	
	Party wall between dwellings - un-filled cavity	<input type="checkbox"/>	<input type="checkbox"/>	<input type="checkbox"/>	

I, as site manager/supervisor (or other suitable project staff member), certify that the selected details (above) have been constructed on site following the corresponding general construction sequence, thermal process sequence, and air barrier sequence to allow the relevant Psi-values to be claimed and therefore used in the energy assessment process. I have read and understood the accompanying guidance including the limits and applicability of modelling.

Name:	
Site name:	
Plot no.:	
Signed:	
Date:	

Appendix C: List of material properties

The thermal modelling contained within this document utilises the following material characteristics, derived from relevant standards, manufacturer declaration, industry guidance, or other available industry information.

Material name	Thermal conductivity (W/mK)	Notes
Blockwork	0.11	Blockwork conductivity will be adjusted by mortar as per BR 497 section 3.1.3.3
	0.15	Blockwork conductivity will be adjusted by mortar as per BR 497 section 3.1.3.3
	0.19	Blockwork conductivity will be adjusted by mortar as per BR 497 section 3.1.3.3
	0.51	
	1.13	
Brickwork	0.77	
Compacted hardcore	2	
Concrete	1.4	
Concrete beams	2	
Concrete floor blocks	1.13	
Dense plaster	0.577	
Flexible roof insulation / ceiling insulation	0.044	
Foundations	2	
Ground / soil	2	Default soil conductivity from BS EN ISO 13370:2017
Insulating expanding foam	0.035	
Kingspan Kooltherm® K103 Floorboard	0.019	
Kingspan Kooltherm® K107 Pitched Roof Board	0.019	
Kingspan Kooltherm® K108 Cavity Board	0.019	
Kingspan Thermaroof® TR26	0.022	
Kingspan Thermaroof® TR27	0.027	(insulant thickness < 80 mm)
	0.025	(insulant thickness 80 - 119 mm)
	0.024	(insulant thickness ≥ 120 mm)
Kooltherm Cavity Closer core	0.022	
Kooltherm Cavity Closer u-PVC extrusion	0.17	
Lintel expanded polystyrene fill	0.032	
Metal lintel	50	
Mortar	0.94	Present only to adjust the thermal conductivity of the blockwork not present in the actual models
Perforated steel base plate (+ lintel plaster key)	6.9	Indicative thermal conductivity as per BR 497 worked example 3
Plasterboard	0.19	
Proprietary insulated fire stop	0.035	
Proprietary insulated fire / acoustic stop	0.044	Thermal conductivity of stop used in party wall models
Screed	1.4	
Timber (inc. plyboard, skirting and soffit board)	0.13	
Trench block	0.24	

Contact details

Kingspan Insulation Ltd

Pembridge | Leominster
Herefordshire | HR6 9LA

T: +44 (0) 1544 388 601

F: +44 (0) 1544 388 888

E: info@kingspaninsulation.co.uk

www.kingspaninsulation.co.uk

For individual department contact details please visit

www.kingspaninsulation.co.uk/contact



Visit our free online U-value calculator.
Offering free, quick and easy calculations
for wall, floor and roof constructions.



For the most up-to-date
version of this brochure
please scan or [click here](#).

To access pre-existing product information or information relating to previously sold/discontinued products please email literature@kingspaninsulation.co.uk.

The information contained in this brochure is believed to be correct at the date of publication. Kingspan Insulation Limited ("Kingspan Insulation") reserves the right to alter or amend the product specifications without notice due to continuous improvement commitments. There may also be relevant changes between publications with regard to legislation, or other developments affecting the accuracy of the information contained in this brochure. Product thicknesses shown in this document should not be taken as being available ex-stock and reference should be made to the current Kingspan Insulation price-list or advice sought from Kingspan Insulation's Customer Service Department. The information, technical details and fixing instructions etc. included in this literature are given in good faith and apply to uses described. Kingspan Insulation does not accept responsibility for issues arising from using products in applications different from those described within this brochure or failure to correctly follow the information or instructions as described within this brochure. Recommendations for use should be verified with a suitable expert or professional for suitability and compliance with actual requirements, specifications and any applicable laws and regulations. For other applications or conditions of use, Kingspan Insulation offers a technical advisory service (see above for contact details), the advice of which should be sought for uses of Kingspan Insulation products that are not specifically described herein. Please check that your copy of this literature is current by contacting the Kingspan Insulation Marketing Department.

© Kingspan, Kooltherm, Thermaroof, Thermataper and the Lion Device are Registered Trademarks of the Kingspan Group plc in the UK, Ireland and other countries. All rights reserved.

TM Therma is a Trademark of the Kingspan Group plc.

Registered in England & Wales, No. 01882722. Registered Office: Pembridge, Leominster, Herefordshire HR6 9LA UK. VAT GB428602456.

