

Insulation
Ireland

Seventh Issue | 03/2026

Thermawall[®] TW52

Insulated plasterboard for plaster
dab / adhesive bonded dry-lining



Contents

Introduction	3
Product details	4
The facings	4
The core	4
Standards & approvals	4
Standard dimensions	4
Compressive strength	4
Durability	4
Resistance to solvents, fungi & rodents	4
Fire performance	5
Thermal properties	5
Typical constructions & U-values	6
Assumptions	6
U-value table key	6
Masonry cavity walls	6
Design considerations	8
Heat loss and linear thermal bridging	8
Reducing linear thermal bridging	8
Responsible sourcing	9
Specification clause	9
Limitations	9
Product classifications	9
Water vapour control / condensation	9
Fire stops	9
Design standards	9
Fixing method	9
Sitework	10
Preparation	10
Mechanical fixing	10
Adhesive bonding	11
Fixing heavy internal fittings	13
Corner and skirting details	14
Window / door reveals, separating/ internal walls and soffit/ head details	14
General	15
About Kingspan Insulation	16
Products & solutions	16
Company details	20
Services	20
Planet Passionate	21
Contact details	22

Introduction

- Rigid thermoset polyisocyanurate (PIR) insulation - thermal conductivity 0.022 W/mK
- Insulation, dry-lining and vapour control in one board
- Allows quick response heating
- Unaffected by air infiltration
- Resistant to the passage of water vapour
- Ideal for new build and refurbishment
- Easy to handle and install compared to some other commonly used insulants



Visit our **free online U-value calculator**.
Offering free, quick and easy calculations
for wall, floor and roof constructions.

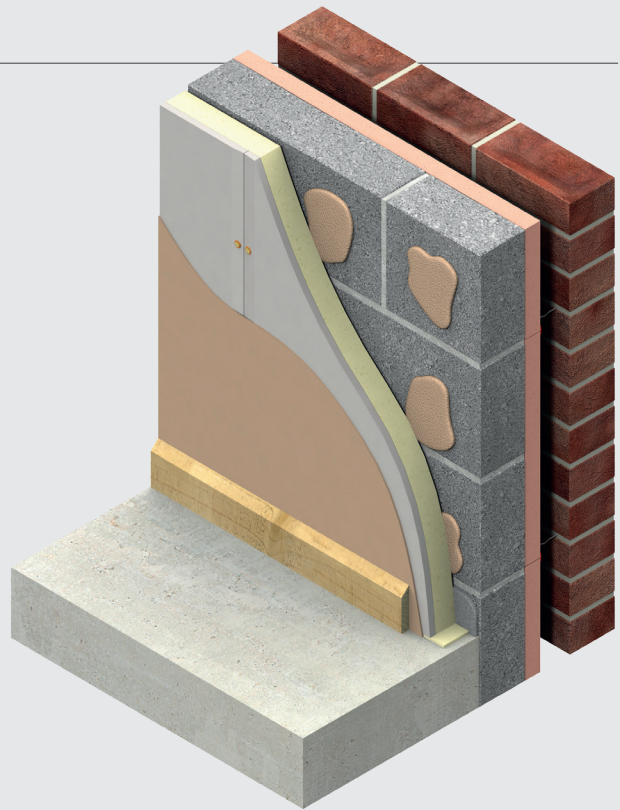

Useful links

Website

[Kingspan Thermawall® TW52 webpage](#)

Declaration of Performance (DoP)

[Kingspan Thermawall® TW52 Declaration of Performance \(CE DoP\)](#)

Product details

The facings

The front face

The front facing of Kingspan Thermawall® TW52 is a tapered edge gypsum based plasterboard which readily accepts dry-jointing materials and plaster skim.

The reverse face

The reverse facing of Kingspan Thermawall® TW52 is a composite of paper and aluminium, autohesively bonded to the insulation core during manufacture.

The core

The core of Kingspan Thermawall® TW52 Insulated Plasterboard is a fibre-free rigid thermoset polyisocyanurate (PIR) insulant.



Standards & approvals

Kingspan Thermawall® TW52 Insulated Plasterboard is manufactured in accordance with the requirements of EN 13165: 2012 + A2: 2016 (Thermal insulation products for buildings. Factory made rigid polyurethane foam (PU) products. Specification).

Kingspan Thermawall® TW52 Insulated Plasterboard is also manufactured under a management system certified to ISO 9001: 2015 (Quality Management System), ISO 14001: 2015 (Environmental Management System), ISO 45001: 2018 (Occupational Health and Safety Management System), ISO 50001: 2018 (Energy Management Systems- Requirements with Guidance for Use) and ISO 37301: 2021 (Compliance Management System).

The use of Kingspan Thermawall® TW52 Insulated Plasterboard produced at Kingspan Insulation's Castleblayney (Co. Monaghan) manufacturing facility is covered by NSAI Agrément Certificate 03/0196.



Standard dimensions

Kingspan Thermawall® TW52 Insulated Plasterboard is available in the following standard size(s):

Nominal dimension		Availability
Length	(mm)	2436
Width	(mm)	1196
Insulant Thickness	(mm)	Refer to local distributor or Kingspan Insulation for current stock and non-stock sizes.

Compressive stress

The average compressive stress of Kingspan Thermawall® TW52 Insulated Plasterboard exceeds 140 kPa at 10% compression, when tested to EN 826: 2013 (Thermal insulating products for building applications. Determination of compression behaviour).

Durability

If correctly installed, Kingspan Thermawall® TW52 Insulated Plasterboard will remain effective for the life of the building. Its durability depends on the supporting structure and the conditions of its use.

Resistance to solvents, fungi & rodents

The insulation core is resistant to short-term contact with petrol and with most dilute acids, alkalis and mineral oils. However, it is recommended that any spills be cleaned off fully before the boards are installed. Ensure that safe methods of cleaning are used, as recommended by the suppliers of the spilt liquid. The insulation core is not resistant to some solvent-based adhesive systems, particularly those containing methyl ethyl ketone. Adhesives containing such solvents should not be used in association with this product. Damaged boards or boards that have been in contact with harsh solvents or acids should not be used.

The insulation core and facings used in the manufacture of Kingspan Thermawall® TW52 resist attack by mould and microbial growth, and do not provide any food value to vermin.

Product details

Fire performance

There are potential restrictions placed upon this product which vary dependant on building type, height, construction and location. Please refer to the relevant Building Regulations

Under System 3 AVCP, Kingspan Thermawall® TW52 Insulated Plasterboard has a Euroclass rating of B-s1,d0.

Further details of the fire performance of Kingspan Insulation products may be obtained from the Kingspan Insulation Technical Service Department (see rear cover for details).

Thermal properties

The λ -values and R-values detailed below are quoted in accordance with EN 13165: 2012 + A2: 2016 (Thermal insulation products for buildings. Factory made rigid polyurethane foam (PU) products. Specification).

Thermal conductivity

The thermal conductivity (λ -value) of the plasterboard component of Thermawall® TW52 is 0.25 W/mK.

The thermal conductivity (λ -value) of the insulation core of Kingspan Thermawall® TW52 is 0.022 W/mK.

Thermal resistance

Thermal resistance (R-value) varies with the thickness of each component. It is calculated by dividing the thickness of each component (expressed in metres) by its thermal conductivity, followed by adding the resulting figures together. The sum is rounded down to the nearest 0.05 (m²K/W).

Insulant thickness (mm)	Thermal resistance (m ² K/W)
25	1.10
30	1.35
38	1.70
50	2.25
60	2.70
70	3.15
80	3.60

Plasterboard component (mm)	Thermal resistance (m ² K/W)
12.5	0.050

NB Product thickness = insulation thickness + 12.5 mm plasterboard.

NB Refer to local distributor or Kingspan Insulation for current stock and non-stock sizes.

Typical constructions and U-values

Assumptions

The U-values in the tables that follow have been calculated using the method detailed in EN ISO 6946: 2017 (Building components and building elements. Thermal resistance and thermal transmittance. Calculation methods). They are valid for the constructions shown in the details immediately above each table.

NB When calculating U-values to EN ISO 6946: 2017, the type of mechanical fixing used may change the thickness of insulation required. The effect of fixings for Kingspan Thermawall® TW52 Insulated Plasterboard has been ignored in these calculations, as the insulation layer penetrated is not the main insulation layer.

NB For the purposes of these calculations the standard of workmanship has been assumed good, and therefore the correction factor for air gaps has been ignored.

NB The figures quoted are for guidance only. If your construction is different from those specified, and / or to gain a comprehensive U-value calculation along with a condensation risk analysis of your project, please consult the Kingspan Insulation Technical Service Department for assistance.

NB There are potential restrictions placed upon this product which vary dependant on building type, height, construction and location. For guidance regarding the routes to compliance for meeting the fire safety requirements of the Building Regulations / Standards, consult the Kingspan Insulation Technical Service Department.

U-value table key

Further information on the applicable notional and area weighted average limiting U-values is available in the relevant geographical documentation:

- Technical Guidance Document L (Dwellings) and Technical Guidance Document L (Buildings other than Dwellings) to the Building Regulations for the Republic of Ireland.
- Technical Booklets F1 & F2 to the Building Regulations for Northern Ireland.

Masonry cavity walls

102.5 mm brick outer leaf / cavity / 100 mm block inner leaf

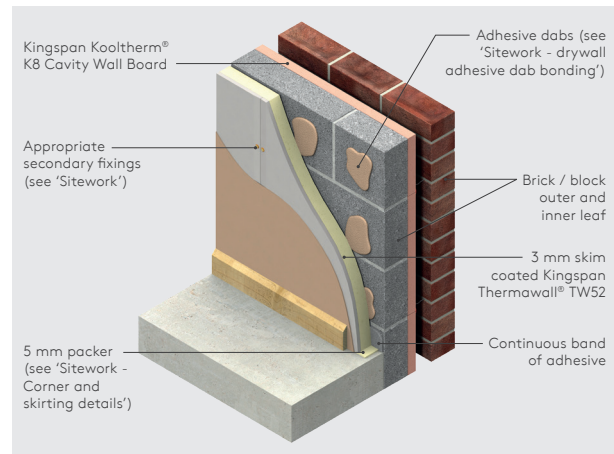

Figure 1

U-values (W/m ² K) for various product thicknesses of Kingspan Thermawall® TW52 Insulated Plasterboard and thicknesses of Kingspan Kooltherm® K8 Cavity Board		
Kingspan Thermawall® TW52 product thickness* (mm)	Inner leaf blockwork density and λ-value (W/mK)	
	Dense (1.13)	Medium (0.51)
100 mm cavity partially filled with 60 mm of Kingspan Kooltherm® K8 Cavity Board**		
37.5	0.20	0.19
42.5	0.19	0.18
50.5	0.18	0.17
62.5	0.16	0.16
72.5	0.15	0.15
82.5	0.14	0.14
92.5	0.13	0.13
150 mm cavity partially filled with 110 mm of Kingspan Kooltherm® K8 Cavity Board**		
37.5	0.13	0.13
42.5	0.13	0.13
50.5	0.12	0.12
62.5	0.12	0.11
72.5	0.11	0.11
82.5	0.10	0.10
92.5	0.10	0.10

* Product thicknesses = insulant thickness + 12.5 mm plasterboard.

** Please read the section entitled 'Residual cavity width' in the literature for Kingspan Kooltherm® K8 for details of cavity width requirements in the Republic of Ireland and Northern Ireland.

NB Refer to local distributor or Kingspan Insulation for current stock and non-stock sizes.

Typical constructions & U-values

20 mm cement rendered / 100 mm block outer leaf / cavity / 100 mm block inner leaf

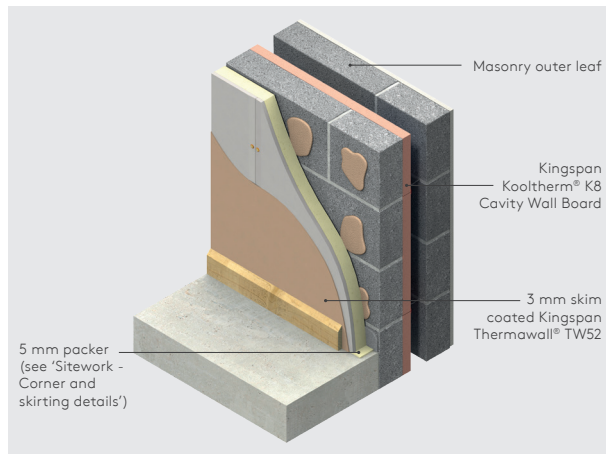

Figure 2

U-values (W/m ² K) for various product thicknesses of Kingspan Thermawall® TW52 Insulated Plasterboard and thicknesses of Kingspan Kooltherm® K8 Cavity Board		
Kingspan Thermawall® TW52 product thickness* (mm)	Inner leaf blockwork density and λ-value (W/mK)	
	Dense (1.13)	Medium (0.51)
100 mm cavity partially filled with 60 mm of Kingspan Kooltherm® K8**		
37.5	0.20	0.19
42.5	0.19	0.18
50.5	0.18	0.17
62.5	0.16	0.16
72.5	0.15	0.15
82.5	0.14	0.14
92.5	0.13	0.13
150 mm cavity partially filled with 110 mm of Kingspan Kooltherm® K8**		
37.5	0.13	0.13
42.5	0.13	0.13
50.5	0.12	0.12
62.5	0.12	0.11
72.5	0.11	0.11
82.5	0.10	0.10
92.5	0.10	0.10

* Product thicknesses = insulant thickness + 12.5 mm plasterboard.

** Please read the section entitled 'Residual cavity width' in the literature for Kingspan Kooltherm® K8 for details of cavity width requirements in the Republic of Ireland and Northern Ireland.

NB Refer to local distributor or Kingspan Insulation for current stock and non-stock sizes.

Design considerations

Heat loss and linear thermal bridging

Basic principles

Linear thermal bridging describes the heat loss at junctions between elements, which is additional to the losses occurring through roofs, walls and floors. This heat loss is represented by the junction's psi (ψ) value. The lower the ψ -value, the better the performance of a junction detail. The ψ -values and lengths of linear thermal bridges are accounted for in a new building's energy and carbon dioxide emissions calculations.

Existing building junction losses are not typically accounted for in whole building heat loss calculations and only the risk of surface condensation and mould growth are considered.

Heat typically flows through the easiest path, for example in a masonry cavity wall the linear thermal bridge is primarily the inner leaf of masonry and in a timber frame wall the linear thermal bridge is primarily the sole plate and the construction below it. These linear thermal bridges can be reduced by increasing the distance that the heat has to travel.

Whilst there are some 'approved' details available, they are specifically targeted at new build constructions. However, where applicable, they are also considered good practice for refurbishment.

Reducing linear thermal bridging

Detailing at junctions to minimise the effects of thermal bridging and the associated risk of condensation or mould growth is important and there are some simple design considerations that can be adopted when insulating internally to help mitigate the risks and to reduce heat loss.

- At a window or door opening, the primary linear thermal bridge is the reveal. This heat loss can be reduced by insulating the reveal. The key factor is the thermal resistance (R-value) of the insulation layer. Reveals should be designed to accommodate 37.5 mm (min.) of Kingspan Thermawall® TW52.
- The application of internal insulation above and below an intermediate floor reduces the overall heat loss, but can increase the losses through the intermediate or separating floor. To reduce these losses, where possible, the edge of the intermediate floor within the floor void should also be insulated.
- Where the properties to both sides of a party wall are to be insulated, best practice to minimise heat losses through the junction with external walls would be to return the insulation back along the party wall for at least 400 mm back from the external wall.
- Where insulating the external walls to only one side of a party wall, and the other property remains uninsulated, it is better not to insulate back along the return, as this can increase the losses to the uninsulated side, increasing the risk of surface condensation and mould growth for the uninsulated property.

For further advice on details to reduce linear thermal bridging please contact the Kingspan Insulation Technical Service Department (see rear cover for details).

Design considerations

Responsible sourcing

Kingspan Thermawall® TW52 Insulated Plasterboard produced at Kingspan Insulation's Castleblayney (Co. Monaghan) manufacturing facility is manufactured under a management system certified to ISO 14001: 2015 (Environmental management systems).

NB The above information is correct at the time of writing. Please confirm at the point of need by visiting the Kingspan Insulation website (see rear cover), from which copies of Kingspan Insulation's certificates can be obtained.

Sustainability & responsibility

Kingspan Insulation has a long-term commitment to sustainability and responsibility: as a manufacturer and supplier of insulation products; as an employer; as a substantial landholder; and as a key member of its neighbouring communities.

Specification clause

Kingspan Thermawall® TW52 should be described in specifications as:-

The wall dry-lining insulation shall be Kingspan Thermawall® TW52 Insulated Plasterboard _____ mm thick: comprising a rigid thermoset polyisocyanurate (PIR) insulation core with 12.5 mm plasterboard bonded to its front surface and a composite of paper and aluminium on its reverse surface. The product shall be manufactured under a management system certified to ISO 9001: 2015, ISO 14001: 2015, ISO 45001: 2018, ISO 50001: 2018 and ISO 37301: 2021; by Kingspan Insulation Limited; and installed in accordance with the instructions issued by them.

Limitations

Kingspan Thermawall® TW52 has a gypsum plasterboard face. It should, therefore, not be used to isolate dampness, nor be used in continuously damp or humid conditions.

When fixing Kingspan Thermawall® TW52 to walls, the boards are normally fixed with their long edges vertical. Boards may be fixed horizontally with an increased number of timber noggins, metal fixing straps or fixing T's. For ceilings, the boards must be installed with the long edge running perpendicular to the joists or rafters (see 'Sitework - Mechanical Fixing - To Timber Framing Studs / Battens').

Water vapour control / condensation

Consideration should be given to the risk of condensation, when designing thermal elements.

When internally lining a construction with insulation, condensation can be controlled by ensuring there is a layer of high vapour resistance on the internal surface of the construction. If required, the vapour resistance of the wall lining can be increased by the application of two coats of Gyproc Drywall Sealer.

A condensation risk analysis should be carried out following the procedures set out in BS 5250: 2021 (Management of moisture in buildings. Code of practice). The Kingspan Insulation Technical Service Department can provide this service.

Fire stops

Current Building Regulations / Standards should be considered with regard to the requirements for and provision of fire stops.

Design standards

BS 8212: 1995 (Code of practice for dry lining and partitioning using gypsum plasterboard).

Fixing method

Kingspan Thermawall® TW52 can be installed utilising either mechanical fixing or adhesive techniques.

Sitework

Preparation

- The existing structure should be surveyed to ensure the construction is capable of supporting the weight of the internal wall system, ancillary items and any post installation fittings.
- Existing wallpaper, skirting, picture rails, gloss paint and projecting window boards may need to be removed. Some internal finishes, such as vinyl wallpaper or gloss paint, can be scored or sanded as an alternative method to removal.
- The wall surface should be clean, stable and free from dust, contamination and loose or friable materials.
- The amount of preparation and removal required will be dependent on the chosen internal wall system.
- Check the structure is dry. Remedial work should be undertaken to remove dampness before installation of the internal wall insulation. Internal wall insulation must not be used to isolate dampness.
- Ensure there are no gaps at the perimeter (including floors, ceilings, internal corners or junctions), or around openings or service penetrations. For optimum airtightness, existing gaps should be sealed using a continuous fillet of drywall adhesive or flexible sealant, before wall lining commences.
- Positions for all new services should be determined.
- Existing services should be assessed to determine any alterations that may need to be made, for example relocating sockets and switches. Wall mounted fixings, such as electrical sockets, should be fitted to take into account the additional wall lining thickness.
- New wall linings must be designed to accommodate The existing structure should be surveyed to ensure the construction is capable of supporting the weight of the internal wall system, ancillary items and any post installation fittings.

Mechanical fixing

To timber framing studs / battens

- This method may be used on timber frame constructions or on dry, stable constructions capable of supporting battens and associated fixings. Timber battens can be packed out using proprietary shims to correct alignment and provide a space to accommodate services.
- Guidelines should be marked out at maximum 600 mm centres to indicate the positioning of the vertical battens.
- Vertical timber framing studs / battens should be set at maximum 600 mm horizontal centres, around the perimeter of the walls, at floor and ceiling, and around any openings and services which penetrate the system.
- If fixing to battens, they should be mechanically fixed to the wall, and comprise 25 x 47 mm (min.) treated softwood, backed with a strip of damp proof course (DPC).
- Each sheet of Kingspan Thermawall® TW52 should lap timber framing studs / battens / noggins by 19 mm (min.) at sheet joints.
- Battens should be fixed approximately 75 mm from the ends of each timber batten and positioned at a maximum 600 mm apart.
- Where joints between sheets of insulated plasterboard are unsupported by the timber framing studs / battens, timber noggins should be installed.
- Each sheet of insulated plasterboard should be lightly butted, with fixings located no less than 10 mm from the bound edges of the sheet.
- Kingspan Thermawall® TW52 should be cut approximately 5 mm short of the floor to ceiling height.
- Sheets of Kingspan Thermawall® TW52 should be located centrally over the timber studs / battens and fixed using either drywall screws at 300 mm centres (or 200 mm at external corners), or large headed galvanised clout nails at 150 mm centres. Each sheet of insulated plasterboard should be lightly butted.
- When installing sheets onto timber, fixings should be long enough to allow minimum 25 mm penetration of the timber frame or minimum 22.5 mm penetration of the the timber battens. Fixings should not penetrate through the battens.
- Fixings should be driven straight, with the heads embedded just below the surface of the plasterboard.
- Care should be taken not to overdrive nails / screws.
- The perimeter of the Kingspan Thermawall® TW52 and the 5 mm clearance gap at the base of the wall should be sealed with a flexible sealant or equivalent.

Sitework

To metal wall liner systems

- This method may be used on any dry, stable constructions capable of supporting the stand-off brackets, tracks and associated fixings. It can be used to correct substantial substrate irregularities, or where a larger cavity is required to accommodate services. Because metal framing systems are proprietary, sitework guidance should be sought from the framing system manufacturer. However, in the absence of any other guidance, the instructions laid out below may be followed.
- The maximum insulation on the wall or service protrusion should be measured to determine the required cavity depth.
- Guidelines should be marked out on the floor and ceiling to indicate where the metal tracks will be positioned.
- The metal tracks should be fixed to the floor, ceiling and perimeters at a maximum of 600 mm centres using appropriate fixings for the proprietary system.
- Vertical guidelines should be marked out on the wall at a maximum 600 mm centres to indicate the position of the lining channels. Horizontal marks should also be made at 800 - 900 mm vertical centres (see manufacturer's details for specific dimensions) to indicate the fixing points for the individual stand-off brackets. Brackets should be fixed using appropriate fixings.
- The lining channels should be fitted and fixed into the metal tracks at ceiling and floor level at a maximum of 600 mm centres, in line with the stand-off bracket positions, using appropriate fixings for the proprietary system, extending if required.
- Bracket legs on the stand-off brackets should be bent forward. Screws should then be inserted through holes in the brackets and fixed to the lining channels using appropriate fixings, such as 13 mm wafer headed drywall screws or jack point screws. Bracket legs can then be bent back to sit clear of the channel face.
- At internal angles or corner, a lining channel or track should be positioned tight into the corner to provide support for the lining.
- Fixing straps or fixing T's should be used to secure unsupported board joints. Metal channels or tracks should also be positioned around the perimeter of openings to support the board.
- Kingspan Thermawall® TW52 should be cut approximately 5 mm short of the floor to ceiling height.
- Kingspan Thermawall® TW52 should be located centrally over the metal lining channels and fixed using self-tapping drywall screws at 300 mm centres (or 200 mm at external corners). Each sheet of insulated plasterboard should be lightly butted.
- Fixings should be located no less than 10 mm from bound edges of the sheet, and be long enough to allow minimum 10 mm penetration of the metal.

- Fixings should be driven straight, with the heads embedded just below the surface of the plasterboard.
- Care should be taken not to overdrive screws.
- The perimeter of Kingspan Thermawall® TW52 and the 5 mm clearance gap at the base of the wall should be sealed with a flexible sealant or equivalent.

Adhesive bonding

Drywall adhesive dab bonding

- Kingspan Thermawall® TW52 is only suitable to dryline new or existing insulated cavity walls or as part of an insulated roof assembly subject to condensation risk analysis, it is not suitable to dryline existing solid wall construction.
- The cavity formed by the dabs can be used to incorporate services less than 25 mm in depth. Alternatively, minimum chasing of the background will be required.
- Minor irregularities of the substrate can be corrected within the dab depth. Typically, gypsum based adhesive should be applied in dabs of 10 - 25 mm thickness, therefore the existing substrate should not exceed a 15 mm tolerance from the high spot of the background to either end of the wall.
- A bonding agent may be required on the substrate to reduce suction or improve mechanical key. This should be applied in continuous bands to correspond with the drywall adhesive dab or band locations.
- A total distance of 10 mm plus the thickness of the Kingspan Thermawall® TW52 boards should be allowed for from the wall's high point. A line should then be drawn across the floor. This should be plumbed for alignment before transferring the line to the ceiling and extending the line to the room corners. Guidelines should also be marked out vertically on the walls at 1,200 mm horizontal centres to indicate where the edges of the Kingspan Thermawall® TW52 boards should finish.
- There are many suitable adhesives that can be used. Once the bonding agent has set, appropriate fixings must then be installed.
- The drywall adhesive should be appropriate for use on the intended masonry substrate. Advice should be sought from the drywall adhesive manufacturer for its recommended system.
- Kingspan Thermawall® TW52 should be cut approximately 5 mm short of the floor to ceiling height.
- A continuous band of drywall adhesive is applied around the perimeter of each wall and around any openings or services, in order to support the insulation board edges and act as a fire stop / cavity barrier if required.
- The adhesive adjacent to the board joints should be applied approximately 25 mm in from the edge of the boards to avoid bridging the joint.

Sitework

- The metal tracks should be fixed to the floor, ceiling and perimeters at a maximum of 600 mm centres using appropriate fixings for the proprietary system.
- Vertical guidelines should be marked out on the wall at a maximum 600 mm centres to indicate the position of the lining channels. Horizontal marks should also be made at 800 - 900 mm vertical centres (see manufacturer's details

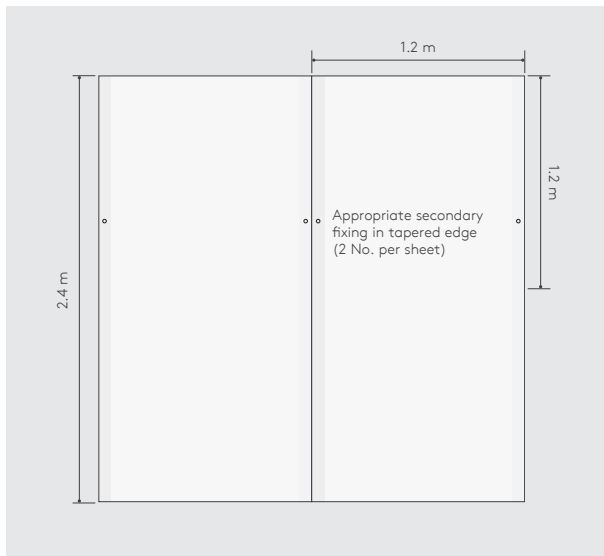

Figure 3: Appropriate secondary fixing pattern

for specific dimensions) to indicate the fixing points for the individual stand-off brackets. Brackets should be fixed using appropriate fixings.

- The lining channels should be fitted and fixed into the metal tracks at ceiling and floor level at a maximum of 600 mm centres, in line with the stand-off bracket positions, using appropriate fixings for the proprietary system, extending if required.
- Bracket legs on the stand-off brackets should be bent forward. Screws should then be inserted through holes in the brackets and fixed to the lining channels using appropriate fixings, such as 13 mm wafer headed drywall screws or jack point screws. Bracket legs can then be bent back to sit clear of the channel face.

- At internal angles or corner, a lining channel or track should be positioned tight into the corner to provide support for the lining.

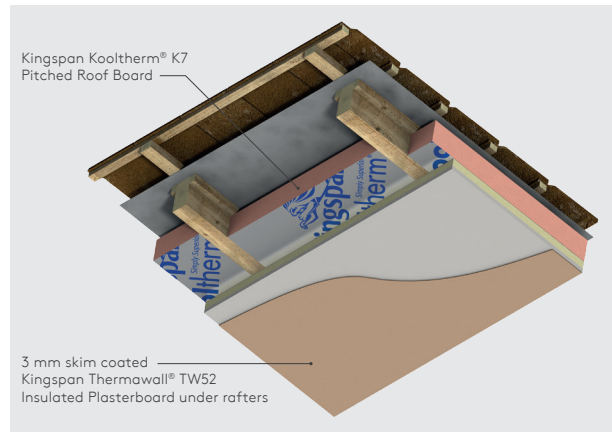

Figure 4: Mechanically fixed to timber rafters with Kingspan Kooltherm® K7 Pitched Roof Board between rafters

- Fixing straps or fixing T's should be used to secure unsupported board joints. Metal channels or tracks should also be positioned around the perimeter of openings to support the board.
- Kingspan Thermawall® TW52 should be cut approximately 5 mm short of the floor to ceiling height.
- Kingspan Thermawall® TW52 should be located centrally over the metal lining channels and fixed using self-tapping drywall screws at 300 mm centres (or 200 mm at external corners). Each sheet of insulated plasterboard should be lightly butted.
- Fixings should be located no less than 10 mm from bound edges of the sheet, and be long enough to allow minimum 10 mm penetration of the metal.
- Fixings should be driven straight, with the heads embedded just below the surface of the plasterboard.
- Care should be taken not to overdrive screws.
- The perimeter of Kingspan Thermawall® TW52 and the 5 mm clearance gap at the base of the wall should be sealed with a flexible sealant or equivalent.

Fixing heavy internal fittings

- Suitable mechanical fixings should be used for heavy internal fittings (kitchen units, shelving etc), to ensure the load is applied direct to the supporting wall and not to the Kingspan Thermawall® TW52 Insulated Plasterboard.

For details on fixings refer to:

MAK Fasteners +353 (0) 1 451 9900
www.makfasteners.com

HILTI 1 850 287387 (ROI)
www.hiltie.ie 0800 886100 (NI)

Tech Fasteners +353 (0) 1 457 33 00
www.techfasteners.ie

Ejot UK Limited +44 (0) 1977 687 040
www.ejot.co.uk

- Alternatively, where there are to be extensive heavy internal fittings, the construction outlined in Figure 5 can be adopted.

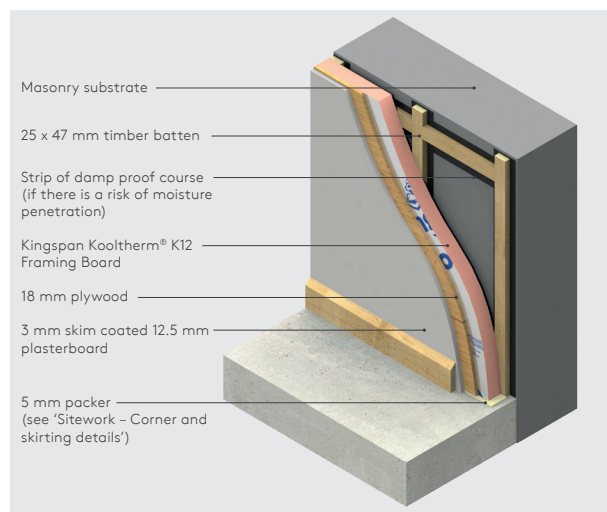

Figure 5: Mechanically fixed construction suitable for heavy internal fittings

- Suitable mechanical fixings should be used for heavy internal fittings.
- Vertical timber framing studs / battens should be set at maximum 600 mm horizontal centres.
- If fixing to battens, they should be mechanically fixed to the wall, and comprise 25 x 47 mm (min.) treated softwood, backed with a strip of damp proof course (DPC).

- Where insulation board joints are unsupported by the timber framing studs / battens, timber noggins should be installed.
- Each insulation board should lap timber framing studs / battens / noggins by 19 mm (min.) at board joints.
- Boards of Kingspan Kooltherm® K12 Framing Board should be temporarily fixed / nailed to timber framing studs / battens.
- 18 mm plywood should then be fixed through insulation boards to the timber framing studs / battens, using either drywall screws at 300 mm centres, or large headed galvanised clout nails at 150 mm centres.
- When fixing plywood through the insulation boards onto timber battens, fixings should be located no less than 10 mm from the edges of the sheets, and be long enough to allow minimum 22.5 mm penetration of the timber. Fixings should not penetrate through the battens.
- Fixings should be driven straight, with the heads embedded just below the surface of the plywood.
- 12.5 mm plasterboard is then fixed to the plywood, using either drywall screws at 300 mm centres, or large headed galvanised clout nails at 150 mm centres.
- Fixings should be driven straight, with the heads embedded just below the surface of the plasterboard.
- Care should be taken not to overdrive nails / screws.
- The 5 mm clearance gap at the base of the wall should be sealed with a flexible sealant or equivalent.
- Heavy fittings can be fixed through the plasterboard directly to the plywood.

Corner and skirting details

- For external corners (including reveals), the lining should run past the corner and the insulating backing of Kingspan Thermawall® TW52 should be cut back to create a junction (see Figures 6 & 8). Sheets should be cut and rebated to allow a plasterboard / plasterboard joint at the angle.
- Ensure sheets are lightly butted and air gaps minimised to reduce the risk of cold bridging (see Figures 6 & 8). Any air gaps should be sealed with flexible sealant or equivalent, or a combination of flexible polyurethane foam and flexible sealant or equivalent.

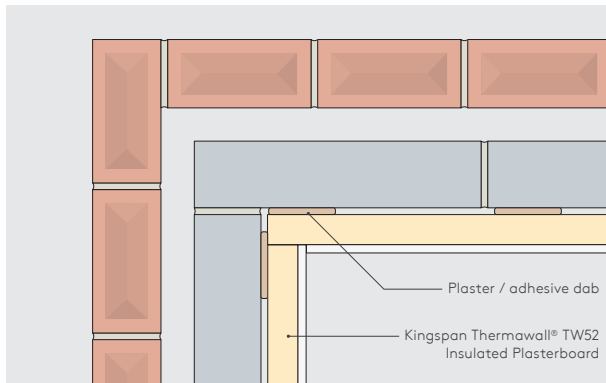

Figure 6: Internal corner detail

- For mechanically fixed applications, a 5 mm packer should be used at the base of the wall to provide a level surface from which to build up the boards.
- The packer should be replaced with a flexible / sealant or equivalent (for 5 mm gaps), or with a combination of flexible polyurethane foam and flexible sealant or equivalent (for 15 mm gaps) (see Figure 7).

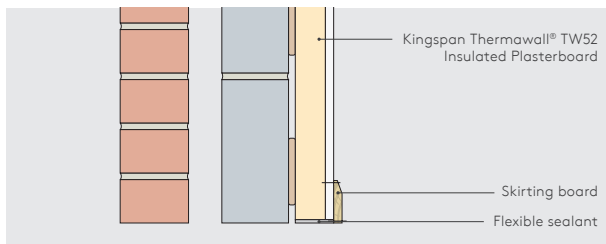

Figure 7: Packer and skirting detail

Window / door reveals, separating/ internal walls and soffit/ head details

- Reveal Lining should be mechanically fixed.
- A 37.5mm sheet of Kingspan Thermawall® TW52 should be used to line the window or door reveals. Where the depth of the window or door frames does not allow for this, the reveal can be cut back or the existing lining can be removed.

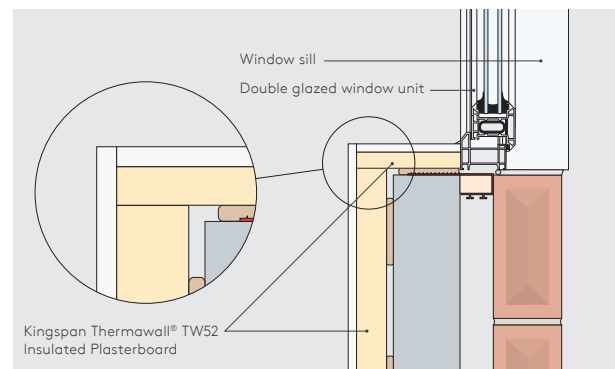

Figure 8: Insulated reveal and external corner

- The junction of the external wall and separating / internal wall should also be insulated with 37.5 mm (min.) of Kingspan Thermawall® TW52, for a minimum distance of 400 mm back from the external all lining.

Finishing

- To avoid air leakage, any penetrations through the insulation (electrical sockets, plumbing and wiring etc) should be sealed with flexible sealant or equivalent, or a combination of flexible polyurethane foam and flexible sealant or equivalent.
- Any remaining gaps between boards / sheets of insulation should be filled with flexible sealant or equivalent, or a combination of flexible polyurethane foam and flexible sealant or equivalent.
- Tapered edged boards allow the employment of standard dry-lining techniques.
- Plasterboard tape should be employed at all board joints, and a plaster skim finish applied.
- The skimming should be carried out in accordance with the specified plaster manufacturer's instructions, particularly in relation to the need to allow thorough drying of the plaster prior to decoration.

Sitework

General

Cutting

- Cutting should be carried out either by using a fine toothed saw or by using a sharp knife to cut through the insulation and paper backing of the plasterboard, then snapping the sheet face down over a straight edge and cutting the paper facing of the plasterboard on the other side.
- Ensure accurate trimming to achieve close butting joints and continuity of insulation.

Availability

- Kingspan Thermawall® TW52 Insulated Plasterboard is available through specialist insulation distributors and selected builders' merchants throughout the Republic of Ireland and Northern Ireland.

Packaging and storage

- The polyethylene packaging of Kingspan Insulation products, which is recyclable, should not be considered adequate for outdoor protection.
- Ideally, boards should be stored inside a building. If, however, outside storage cannot be avoided, then the boards should be stacked clear of the ground and covered with an opaque polythene sheet or weatherproof tarpaulin. Boards that have been allowed to get wet should not be used.

Health and safety

- Kingspan Insulation products are chemically inert.
- A Safety Information Data Sheet for this product is available from the Kingspan Insulation website www.kingspaninsulation.ie/downloads.
- Warning - do not stand on or otherwise support your weight on this product unless it is fully supported by a load bearing surface.

About Kingspan Insulation

Solutions available for roofs, walls and floors of commercial buildings, from schools to retail.

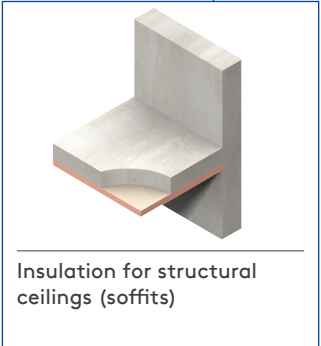
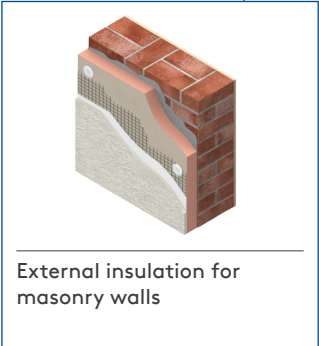
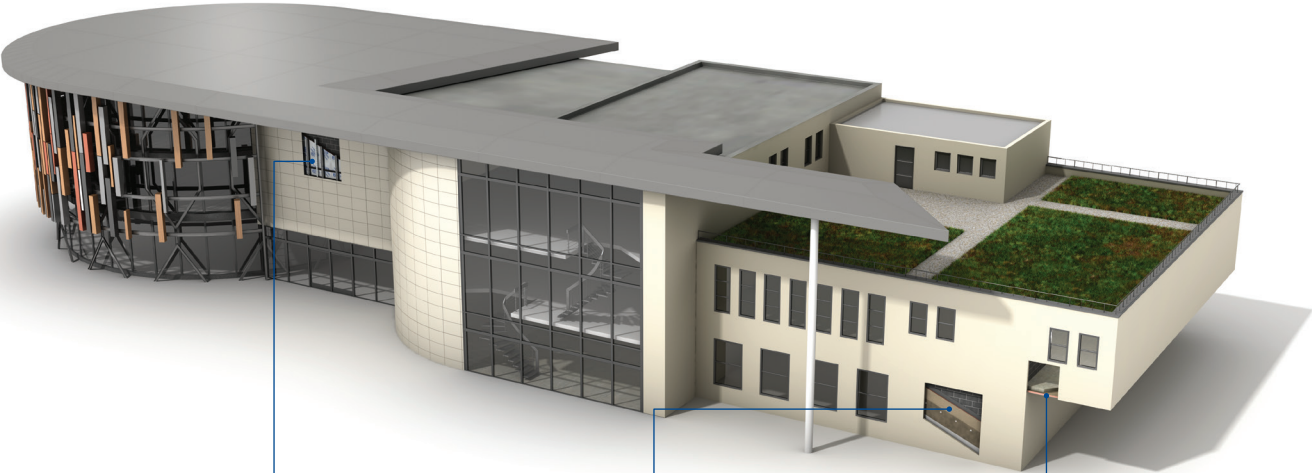

About Kingspan Insulation

From new housing developments to refurbishing your home, we offer a number of different solutions for roof, wall and floor applications.

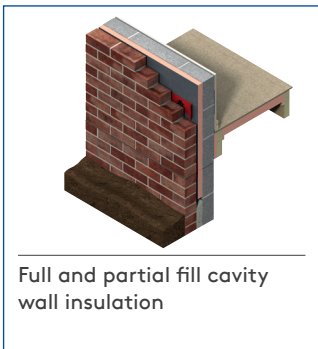
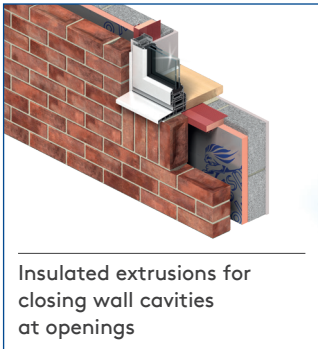

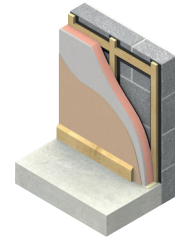

Insulation for tiled or slated pitched warm roof spaces

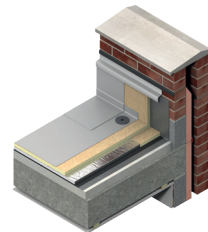

Insulation for flat roofs and terraces

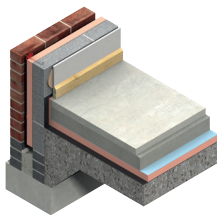

Insulation for floors

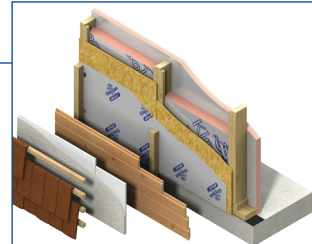

Insulation for timber and steel framing systems

About Kingspan Insulation

Company details

Kingspan Insulation Ltd is part of the Kingspan Group plc., one of Europe's leading construction product manufacturers. The Kingspan Group was formed in the late 1960s and is a publicly quoted group of companies headquartered in Kingscourt, County Cavan, Ireland.



Kingspan Insulation Ltd is a leading manufacturer of rigid insulation products and insulated systems for building fabric and building services applications.

Our site in Castleblayney, Ireland, is accredited to the independent compliance standard ISO 37301: 2021.



Services

Our support services provide fast and accurate advice no matter what your role is. Visit our website to access the following services.

- U-value calculations – free, quick and easy U-value calculations with our U-value Calculator.
- Help and advice on your projects, including stockists, how to guides, regulatory guidance and e-learning.
- Dedicated Specification and Sales teams to support projects.
- Building Information Modelling (BIM) – download BIM objects for our products.
- Tapered roofing service – Kingspan Insulation's tapered roofing systems come with a supporting design service to ensure the most cost-effective solution for a roof is identified.



- CPDs – Kingspan Insulation offers a number of free CPD seminars for architects and specifiers covering a wide range of industry topics. CPDs can be booked or a range of courses can be found online.



PLANET PASSIONATE

Planet Passionate is our group wide global sustainability programme.

Our Planet Passionate programme aims to have a positive impact on three big global challenges: climate change, circularity and protection of our natural world.



Scan for our latest progress report to learn more about our targets, partnerships and global commitments.

Contact details

Kingspan Insulation Ltd

Castleblayney | County Monaghan

T: +353 (0) 42 979 5000

E: info@kingspaninsulation.ie

www.kingspaninsulation.ie

For individual department contact details please visit
www.kingspaninsulation.ie/contact



Visit our free online U-value calculator.
Offering free, quick and easy calculations
for wall, floor and roof constructions.



For the most up-to-date
version of this brochure
please scan or click [here](#).

To access pre-existing product information or information relating to previously sold/discontinued products please email literature@kingspaninsulation.ie.

The information contained in this brochure is believed to be correct at the date of publication. Kingspan Insulation Limited ("Kingspan Insulation") reserves the right to alter or amend the product specifications without notice due to continuous improvement commitments. There may also be relevant changes between publications with regard to legislation, or other developments affecting the accuracy of the information contained in this brochure. Product thicknesses shown in this document should not be taken as being available ex-stock and advice should be sought from Kingspan Insulation's Customer Service Department. The information, technical details and fixing instructions etc. included in this literature are given in good faith and apply to uses described. Kingspan Insulation does not accept responsibility for issues arising from using products in applications different from those described within this brochure or failure to correctly follow the information or instructions as described within this brochure. Recommendations for use should be verified with a suitable expert or professional for suitability and compliance with actual requirements, specifications and any applicable laws and regulations. For other applications or conditions of use, Kingspan Insulation offers a technical advisory service (see above for contact details), the advice of which should be sought for uses of Kingspan Insulation products that are not specifically described herein. Please check that your copy of this literature is current by contacting the Kingspan Insulation Marketing Department.

© Kingspan, Thermawall, AlphaCore, K-Roc, Kingspan GREENGUARD, Kooltherm, OPTIM-R, TEK and the Lion Device are Registered Trademarks of the Kingspan Group plc in the UK, Ireland and other countries. All rights reserved.

TM Therma is a Trademark of the Kingspan Group plc.

Kingspan Insulation Ltd is not associated with, and its products have not necessarily been tested by, the GREENGUARD Environmental Institute.

Registered in Ireland, No. 54621. Registered Office: Bree Industrial Estate, Castleblayney, Co. Monaghan, Ireland. VAT IE4575069I.

