

UL INTERNATIONAL (UK) LTD  
 Kingsland Business Park,  
 Unit 1-3 Horizon,  
 Wade Rd,  
 Basingstoke RG24 8AH,  
 United Kingdom

appointed according to Article 29 of Construction Products Regulation 2011 as amended by the Construction Products (Amendment etc.) (EU Exit) Regulations 2019 and the Construction Products (Amendment etc.) (EU Exit) Regulations 2020

<b>UK Technical Assessment</b>	<b>0843-UKTA-23/0011 of 09/07/2025</b>
--------------------------------	--

<b>Technical Assessment Body Issuing the UKTA:</b>	UL International (UK) Ltd
<b>Trade name of the construction product</b>	Kingspan K-Stop® Intumescent Mastic Plus
<b>Product family to which the construction product belongs</b>	Fire Stopping and Sealing Product: <ul style="list-style-type: none"> <li>• Linear Joint and Gap Seals</li> </ul>
<b>Manufacturer</b>	Kingspan Technical Insulation Ltd Harvey Rd Basildon SS13 1QJ
<b>Manufacturing plant(s)</b>	A/003
<b>This UK Technical Assessment contains</b>	16 pages including 1 Annex which forms an integral part of this assessment.
<b>This UK Technical Assessment* is issued, on the basis of</b>	EAD 350141-00-1106, September 2017.
<b>This version replaces</b>	0843-UKTA-23/0011 issued on 16/08/2023

Translations of this UK Technical Assessment in other languages shall fully correspond to the original issued document and should be identified as such.

Communication of this UK Technical Assessment, including transmission by electronic means, shall be in full. However, partial reproduction may be made, with the written consent of the issuing Technical Assessment Body. Any partial reproduction shall be identified as such.

\* in accordance with Construction Products Regulation 2011 as amended by the Construction Products (Amendment etc.) (EU Exit) Regulations 2019 and the Construction Products (Amendment etc.) (EU Exit) Regulations 2020

## **Table of Contents**

<b>I.</b>	<b>SPECIFIC PARTS OF THE UK TECHNICAL ASSESSMENT .....</b>	<b>3</b>
1	Technical description of the product .....	3
2	Specification of the intended uses of the product in accordance with the applicable UK Assessment Document (Pre-Exit European Assessment Document): EAD 350141-00-1106, September 2017 .....	3
3	Performance of the product and references to the methods used for its assessment .....	5
4	ASSESSMENT AND VERIFICATION OF CONSTANCY OF PERFORMANCE (HEREINAFTER AVCP) SYSTEM APPLIED, WITH REFERENCE TO ITS LEGAL BASE .....	6
5	Technical details necessary for the implementation of the AVCP system, as provided for in the applicable EAD .....	6
6	Issued on:.....	7
<b>ANNEX A – Resistance to Fire Classification – Kingspan K-Stop® Intumescent Mastic Plus .....</b>	<b>8</b>	
A.1	Flexible wall constructions according to 2.1) with wall thickness of minimum 75 mm and minimum 1 x layer of 12.5 mm board per side.....	8
A.1.1	Linear joint seals, between head of flexible wall and soffit of concrete floor and vertical end of flexible wall and concrete wall .....	8
A.2	Flexible wall constructions according to 1.2.1 with wall thickness of minimum 100 mm and minimum 2 x layer of 12.5 mm board per side.....	9
A.2.1	Linear joint seals, between head of flexible wall and soffit of concrete floor and vertical end of flexible wall and concrete wall .....	9
A.2.2	Flexible or rigid wall construction with wall thickness of minimum 100 mm and timber substrates and architraves .....	10
A.2.2.1	Linear joint or gap seals, vertically or horizontal orientated with backing materials .....	10
A.2.3	Flexible or rigid wall construction with wall thickness of minimum 100 mm and timber substrates .....	11
A.2.3.1	Linear joint or gap seals, vertically or horizontal orientated with backing materials .....	11
A.2.4	Flexible or rigid wall construction with wall thickness of minimum 100 mm and steel substrates .....	12
A.2.4.1	Linear joint or gap seals, vertically or horizontal orientated with backing materials .....	12
A.2.5	Linear joint or gap seals, vertically or horizontal orientated with backing materials .....	13
A.3	Rigid wall constructions according to 1.2.1 with wall thickness of minimum 150 mm .....	14
A.3.1	Linear joint or gap seal, between head of rigid wall and soffit of concrete floor / between rigid walls .....	14
A.4	Rigid floor constructions according to 1.2.1 with floor thickness of minimum 150 mm.....	15
A.4.1	Linear joint or gap seal, between floor slabs or between floor slab and wall with sealant to the top face of the floor only .....	15
A.4.2	Linear joint or gap seals, in or between rigid floors .....	16

## I. SPECIFIC PARTS OF THE UK TECHNICAL ASSESSMENT

### 1 Technical description of the product

- 1) Kingspan K-Stop® Intumescent Mastic Plus is an intumescent acrylic sealant used to form linear gap seals where gaps are present in wall and floor constructions and linear joint seals where wall and floor constructions abut.
- 2) The Kingspan K-Stop® Intumescent Mastic Plus is supplied in liquid form contained within 310 & 380 ml cartridges and 600 ml foil packs. The sealant is gunned into the aperture in the separating element/elements and around the service or services, to a specified depth utilising a backing material.
- 3) Kingspan K-Stop® Intumescent Mastic Plus contains no carcinogenic substances or mutagenic substances, flame retardants or antimicrobiological agents.
- 4) The applicant has submitted a written declaration that Kingspan K-Stop® Intumescent Mastic Plus does not contain substances which have to be classified as dangerous according to Directive 67/548/EEC and Regulation (EC) No 1272/2008 and listed in the "Indicative list on dangerous substances" of the EGDS - taking into account the installation conditions of the construction product and the release scenarios resulting from there.

In addition to the specific clauses relating to dangerous substances contained in this United Kingdom technical Assessment, there may be other requirements applicable to the products falling within its scope (e.g. transposed European legislation and national laws, regulations and administrative provisions). In order to meet the provisions of the Construction Products Regulation, these requirements need also to be complied with, when and where they apply.

- 5) The use category of Kingspan K-Stop® Intumescent Mastic Plus in relation to BWR 3 (Hygiene, health and environment) is IA1 S/W2.

### 2 Specification of the intended uses of the product in accordance with the applicable UK Assessment Document (Pre-Exit European Assessment Document): EAD 350141-00-1106, September 2017

Detailed information and data is given in Annex A.

The intended use of system Kingspan K-Stop® Intumescent Mastic Plus is to reinstate the fire resistance performance of gaps in and joints in and between flexible wall and rigid wall constructions, gaps in and joints between rigid floor constructions.

- 1) The specific elements of construction that the system Kingspan K-Stop® Intumescent Mastic Plus may be used to provide a gap or joint seal in, are as follows:

Flexible walls:	The wall must have a minimum thickness of 75 mm and comprise steel or wooden studs lined on both faces with minimum 1 layers of 12.5 mm thick boards. The wall is permitted with or without insulation material between the boards.
Rigid walls:	The wall must have a minimum thickness of 75 mm and comprise concrete, aerated concrete or masonry, with a minimum density of 650 kg/m <sup>3</sup> .
Rigid floors:	The floor must have a minimum thickness of 150 mm and comprise aerated concrete or concrete with a minimum density of 650 kg/m <sup>3</sup> .

The supporting construction must be classified in accordance with EN 13501-2 for the required fire resistance period.

- 2) The system Kingspan K-Stop® Intumescent Mastic Plus may be used to provide a linear joint or gap seal with specific supporting constructions and substrates (for details see Annex A).

Kingspan Technical Insulation Ltd Fire Protection Systems which involve linear seals on both sides of a flexible wall may also be used in the situation where the linear seal is on one side of the wall only and the remaining side of the wall is not punctured at the same point. All fire integrity and thermal insulation ratings for such single-sided linear seals remain the same as for the equivalent double-sided linear seal.

- 3) The maximum permitted joint/gap width for system Kingspan K-Stop® Intumescent Mastic Plus is 100 mm.
- 4) The maximum movement capability of system Kingspan K-Stop® Intumescent Mastic Plus is  $\leq$  7.5% (not tested to EAD 350141-00-1106).
- 5) The provisions made in this United Kingdom Technical Assessment are based on an assumed working life of the Kingspan K-Stop® Intumescent Mastic Plus of 25 years, provided that the conditions laid down in sections 4.2/5.1/5.2 for the packaging/transport/storage/installation/use/repair are met. The indications given on the working life cannot be interpreted as a guarantee given by the producer, but are to be regarded only as a means for choosing the right products in relation to the expected economically reasonable working life of the works.
- 6) Type Z<sub>2</sub>: Intended for uses in internal conditions with humidity lower than 85 % RH excluding temperatures below 0°C, without exposure to rain or UV.

### 3 Performance of the product and references to the methods used for its assessment

Product-type: Sealant		Intended use: Linear Joint & Gap Seal	
Basic requirement for construction work	Essential characteristic	Performance	
<b>BWR 2 Safety in case of fire</b>			
EN 13501-1	Reaction to fire	Class B-s1, d0	
EN 13501-2	Resistance to fire	Annex A	
<b>BWR 3 Hygiene, health and environment</b>			
Declaration of manufacturer & EN 16516	Content, emission and/or release of dangerous substances	Use categories: IA1 Declaration of manufacturer	
EN 1026:2000	Air permeability (material property)	No performance determined	
EAD 350141-00-1106, Annex C & EN 12390-8	Water permeability (material property)	No performance determined	
<b>BWR 4 Safety in use</b>			
EOTA TR 001:2003	Mechanical resistance and stability	No performance determined	
EOTA TR 001:2003	Resistance to impact/movement	No performance determined	
EOTA TR 001:2003 ISO 11600 & EAD 350141-00-1106, Clause 2.2.13	Adhesion	No performance determined	
EAD 350141-00-1106, Clause 2.2.12	Durability	Z <sub>2</sub>	
EAD 350141-00-1106, Clause 2.2.13	Movement capacity	No performance determined	
EAD 350141-00-1106, Clause 2.2.14	Cycling of perimeter seals for curtain walls	No performance determined	
EAD 350141-00-1106, Clause 2.2.15	Compression set	No performance determined	
EAD 350141-00-1106, Clause 2.2.16	Linear expansion on setting	No performance determined	
<b>BWR 5 Protection against noise</b>			
EN 10140-1,2,4,5/ EN ISO 717-1	Airborne sound insulation	Rw(C;Ctr)= 62 (-1;-5) dB*	
<b>BWR 6 Energy economy and heat retention</b>			
EN 12664, EN 12667, EN 12939, EN ISO 8990, EN ISO 6946, EN ISO 10456	Thermal properties	No performance determined	
EN ISO 12572, EN 12086, EN ISO 10456	Water vapour permeability	No performance determined	

\* At 12 mm depth

**4 ASSESSMENT AND VERIFICATION OF CONSTANCY OF PERFORMANCE (HEREINAFTER AVCP) SYSTEM APPLIED, WITH REFERENCE TO ITS LEGAL BASE**

According to the Statutory Instrument 2019 No. 465 – made 5<sup>th</sup> March 2019 and cited as the Construction Products (Amendment etc.) (EU Exit) Regulations 2019 and coming into force on exit day and Statutory Instrument 2020 No. 1359 – made 26<sup>th</sup> November 2020 and cited as the Construction Products (Amendment etc.) (EU Exit) Regulations 2020 and coming into force immediately before the 2019 Regulations come into force, on the procedure for attesting the conformity of construction products as regards fire stopping, fire sealing and fire protective products, published as ‘Pre-Exit’ European Assessment Documents, (see <https://www.gov.uk/guidance/pre-exit-european-assessment-documents-construction-products>), the system of assessment and verification of constancy of performance (see Annex V to Construction Products Regulation 2011 as amended by the Construction Products (Amendment etc.) (EU Exit) Regulations 2019 and the Construction Products (Amendment etc.) (EU Exit) Regulations 2020) given in the following table(s) apply.

<b>Product(s)</b>	<b>Intended use(s)</b>	<b>Level(s) or class(es)</b>	<b>System(s)</b>
Fire stopping and Fire Sealing Products	For fire compartmentation and/or fire protection or fire performance	Any	1

**5 Technical details necessary for the implementation of the AVCP system, as provided for in the applicable EAD**

**Tasks of the manufacturer:**

Factory production control

The manufacturer shall exercise permanent internal control of production. All the elements, requirements and provisions adopted by the manufacturer shall be documented in a systematic manner in the form of written policies and procedures, including records of results performed. This production control system shall ensure that the product is in conformity with this UK Technical Assessment.

The factory production control shall be in accordance with the Control Plan of 25<sup>th</sup> June 2024 relating to the UK Technical Assessment 0843-UKTA-23/0011 issued on 09/07/2025 which is part of the technical documentation of this UK technical Assessment. The "Control Plan" is laid down in the context of the factory production control system operated by the manufacturer and deposited at UL International (UK) Ltd.

The results of factory production control shall be recorded and evaluated in accordance with the provisions of the Control Plan.

**Other tasks of the manufacturer:**

Additional information

The manufacturer shall provide a technical data sheet and an installation instruction with the following minimum information:

(a) Technical data sheet:

- Field of application:
- Building elements for which the penetration seal is suitable, type and properties of the building elements like minimum thickness, density, and - in case of lightweight constructions – the construction requirements.
- Limits in size, minimum thickness etc. of the penetration seal
- Construction of the penetration seal including the necessary components and additional products (e.g. backfilling material) with clear indication whether they are generic or specific.
- Services which the penetration seal is suitable, type and properties of the services like material, diameter, thickness etc. in case of pipes including insulation materials; necessary/allowed supports/fixings (e.g. pipe trays)

(b) Installation instruction:

- Steps to be followed
- Procedure in case of retrofitting
- Stipulations on maintenance, repair and replacement

**6 Issued on:**

**9<sup>th</sup> July 2025**

Report by:



D. Yates  
Staff Engineer  
Built Environment

Reviewed by:



C. Johnson  
Senior Staff Engineer  
Built Environment

**For and on behalf of UL International (UK) Ltd.**

# ANNEX A – Resistance to Fire Classification – Kingspan K-Stop® Intumescent Mastic Plus

**A.1 Flexible wall constructions according to 2 1) with wall thickness of minimum 75 mm and minimum 1 x layer of 12.5 mm board per side**

**A.1.1 Linear joint seals, between head of flexible wall and soffit of concrete floor and vertical end of flexible wall and concrete wall**

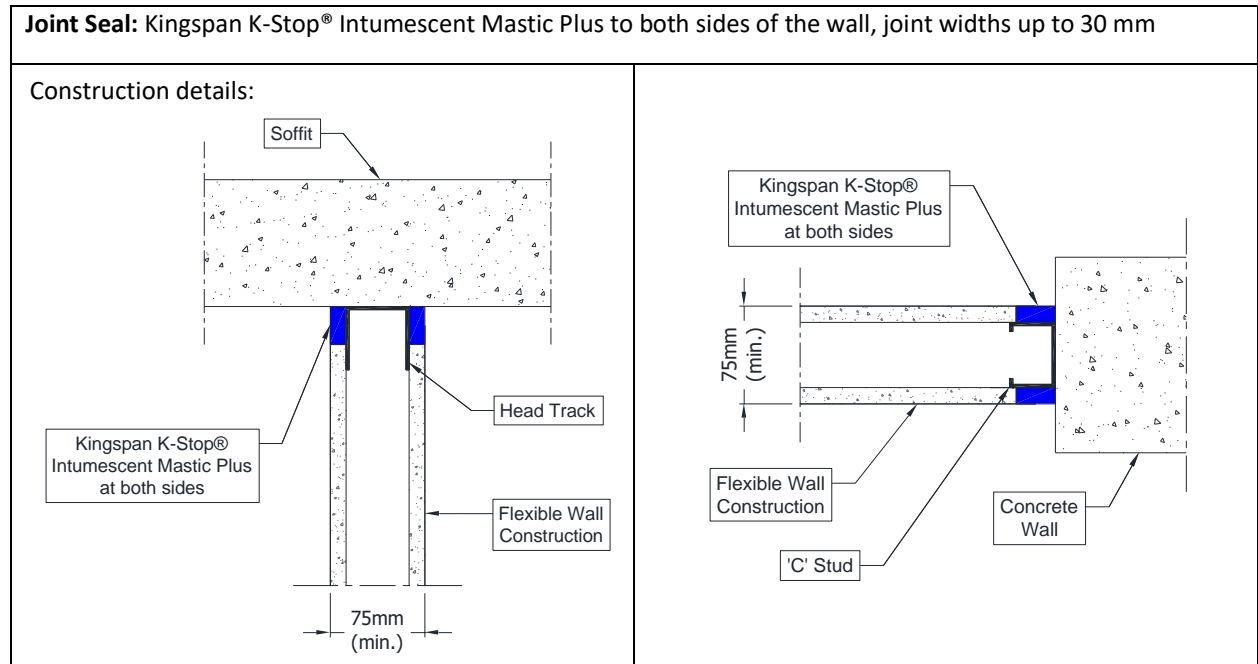

## A.1.1.1

Substrate	Depth (mm)	Backing (minimum)	Classification
Plasterboard / concrete	12.5 min.	50 mm steel partition head track/ stud	E 60 – T – X – F – W 25 EI 45 – T – X – F – W 25
			E 60 – V – X – F – W 15 EI 45 – V – X – F – W 15

**A.2 Flexible wall constructions according to 1.2.1 with wall thickness of minimum 100 mm and minimum 2 x layer of 12.5 mm board per side**

**A.2.1 Linear joint seals, between head of flexible wall and soffit of concrete floor and vertical end of flexible wall and concrete wall**

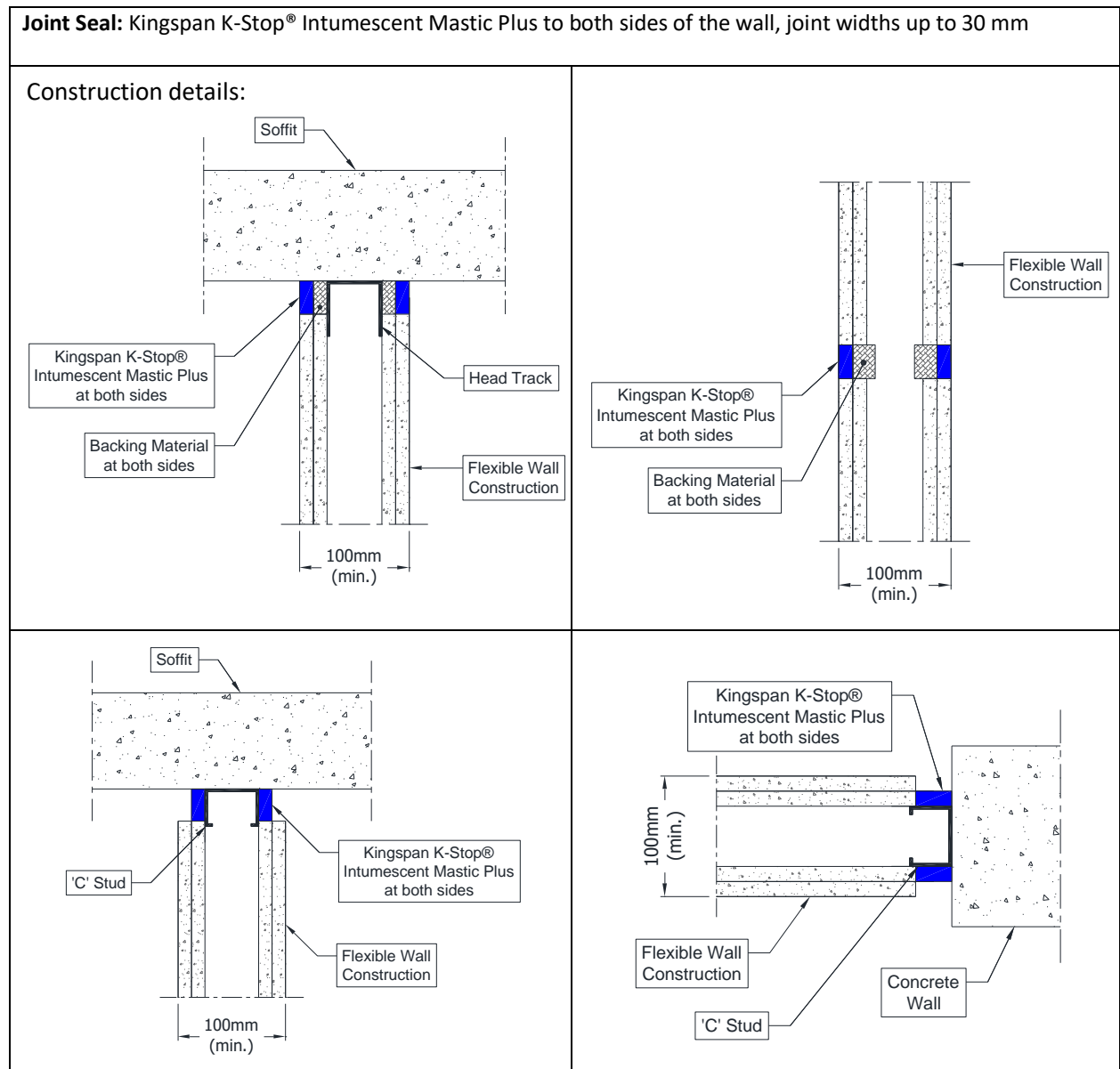

**A.2.1.1**

Substrate	Depth (mm)	Backing (minimum)	Classification
Plasterboard / concrete	12.5 min.	12.5 mm Stone wool 35 kg/m <sup>3</sup> plus 50 mm steel partition head track	EI 120 – T – X – F – W 30
		20 mm Stone wool 35 kg/m <sup>3</sup>	EI 120 – V – X – F – W 30
	25 min.	50 mm steel partition head track	EI 120 – T – X – F – W 30
	12.5 min.	/stud	EI 90 – T – X – F – W 25
			EI 90 – V – X – F – W 15

**A.2.2 Flexible or rigid wall construction with wall thickness of minimum 100 mm and timber substrates and architraves**

**A.2.2.1 Linear joint or gap seals, vertically or horizontal orientated with backing materials**

**Joint Seal:** Kingspan K-Stop® Intumescent Mastic Plus to one side of the wall, joint widths up to 30 mm

Construction details:

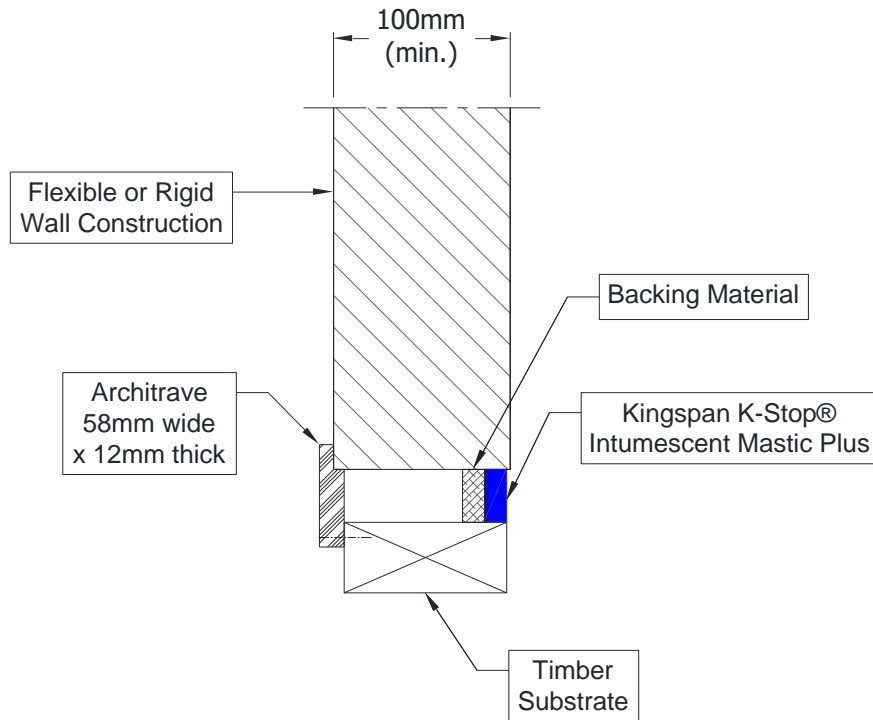

**A.2.2.2**

Substrate	Depth (mm)	Facing (minimum)	Backing	Classification
Flexible or rigid wall / Timber	12.5 min.	Single sided linear seals in flexible or rigid walls against wooden frames covered with architraves on the other side fixed with 25 mm steel pins at nominal 300 mm centres.	Stonewool, 12.5 mm deep min. 35 kg/m <sup>3</sup>	<b>EI 60 – V – X – F – W 30</b>
				<b>EI 60 – T – X – F – W 30</b>

**A.2.3 Flexible or rigid wall construction with wall thickness of minimum 100 mm and timber substrates**

**A.2.3.1 Linear joint or gap seals, vertically or horizontal orientated with backing materials**

**Joint Seal:** Kingspan K-Stop® Intumescent Mastic Plus to both sides of the wall, joint widths up to 30 mm

Construction details:

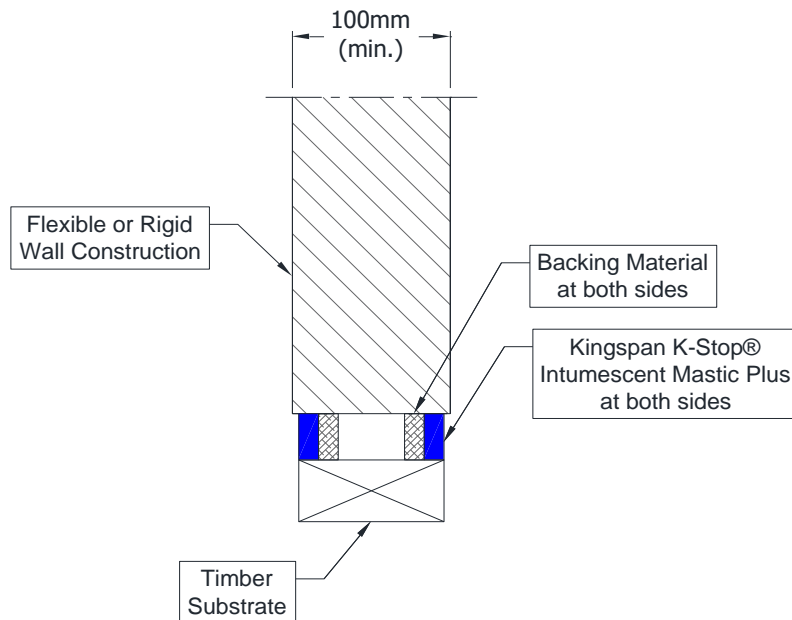

**A.2.3.2**

Substrate	Depth (mm)	Backing	Classification
Flexible or rigid wall / Timber	12.5 min.	Stonewool, 12.5 mm deep min. 35 kg/m <sup>3</sup>	E 90 – V – X – F – W 30
			EI 60 – V – X – F – W 30
			E 90 – T – X – F – W 30
			EI 60 – T – X – F – W 30

**A.2.4 Flexible or rigid wall construction with wall thickness of minimum 100 mm and steel substrates**

**A.2.4.1 Linear joint or gap seals, vertically or horizontal orientated with backing materials**

**Joint Seal:** Kingspan K-Stop® Intumescent Mastic Plus to one side of the wall, with joint widths up to 30 mm.

Construction details:

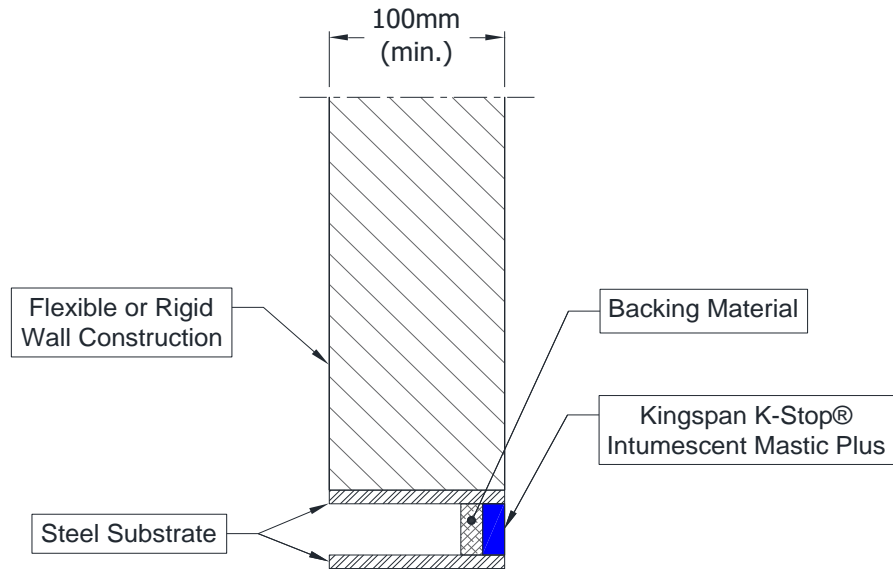

**A.2.4.2**

Substrate	Depth (mm)	Backing	Classification
Steel / steel	12.5 min.	Stonewool, 12.5 mm deep min. 35 kg/m <sup>3</sup>	E 120 – V – X – F – W 30
			EI 30 – V – X – F – W 30
Steel / steel	12.5 min.	Stonewool, 12.5 mm deep min. 35 kg/m <sup>3</sup>	E 120 – T – X – F – W 30
			EI 30 – T – X – F – W 30

### A.2.5 Linear joint or gap seals, vertically or horizontal orientated with backing materials

**Joint Seal:** Kingspan K-Stop® Intumescent Mastic Plus to both sides of the wall, with joint widths up to 30 mm.

Construction details:

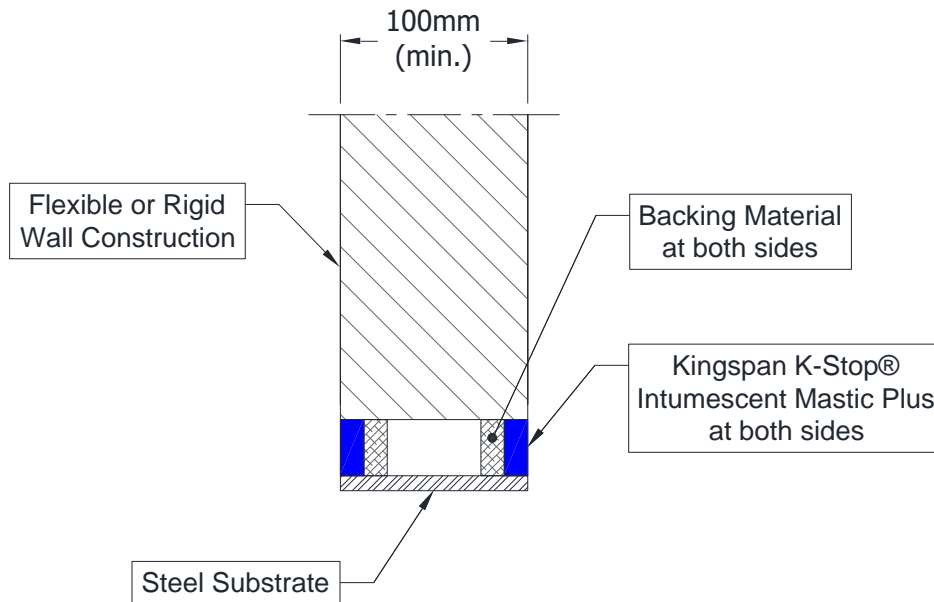

#### A.2.5.1

Substrate	Depth (mm)	Backing	Classification
Flexible or rigid wall / Steel	12.5 min.	Stonewool, 12.5 mm deep min. 35 kg/m <sup>3</sup>	E 120 – V – X – F – W 30 <sup>1</sup> EI 30 – V – X – F – W 30 <sup>2</sup>
			E 120 – T – X – F – W 30 <sup>3</sup> EI 45 – T – X – F – W 30 <sup>4</sup>

\*Additional and for information only.

The classifications provided in Table A.2.5.1 consider the insulation performance of all components within the firestopping system as per the requirements of EN 1366-4. This includes temperature evaluation of the steel substrate.

In relation to each of the above classifications, temperatures recorded on the seal (exclusive of the supporting construction) exceeded the maximum allowable after the following times (rounded down):

<sup>1</sup> 120, <sup>2</sup> 90, <sup>3</sup> 120, <sup>4</sup> 60

### A.3 Rigid wall constructions according to 1.2.1 with wall thickness of minimum 150 mm

#### A.3.1 Linear joint or gap seal, between head of rigid wall and soffit of concrete floor / between rigid walls

**Joint Seal:** Kingspan K-Stop® Intumescent Mastic Plus to either side (or any position between) or both sides of the wall, joint widths up to 30 mm

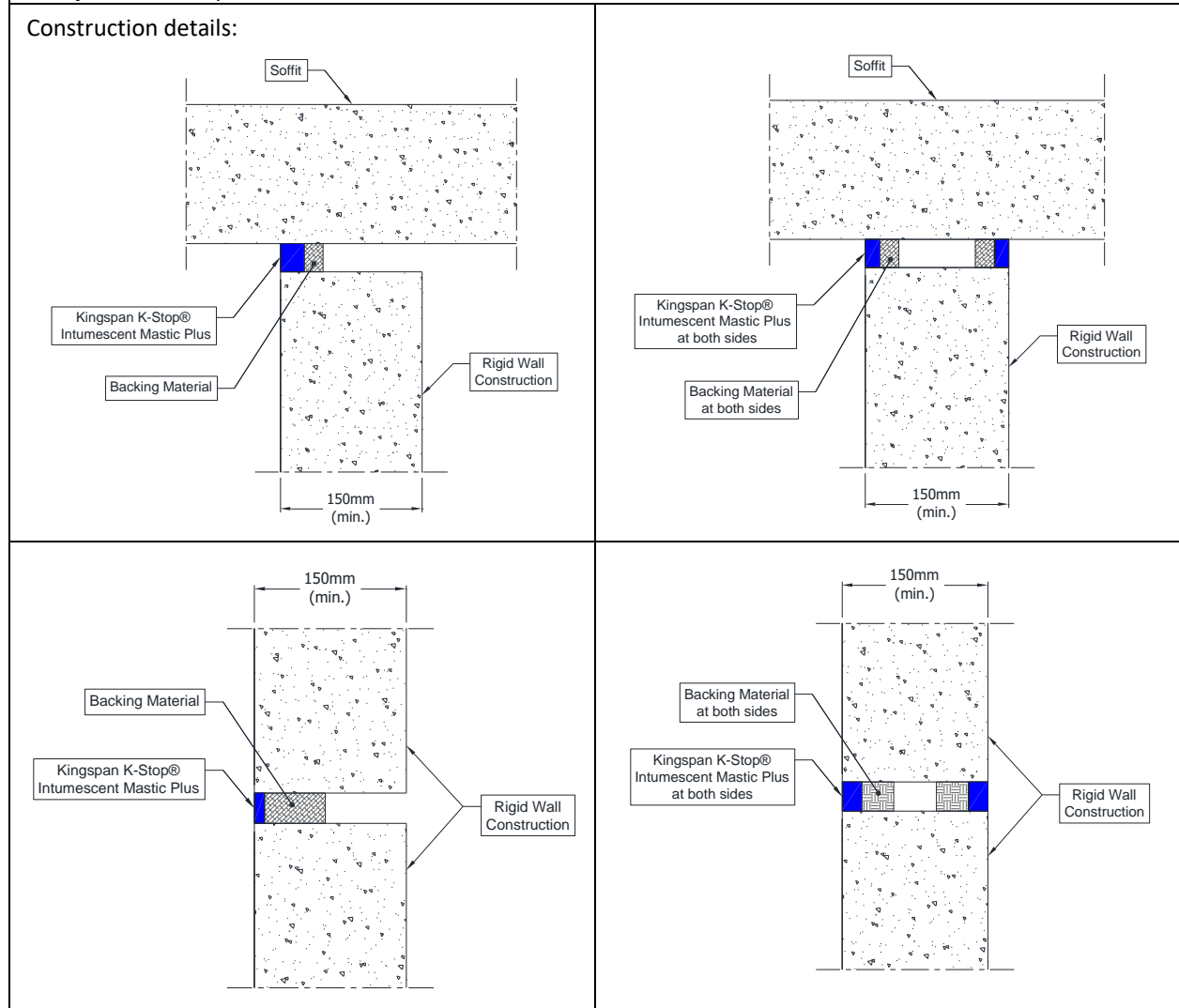

#### A.3.1.1

Substrate	Depth (mm)	Backing (minimum)	Classification
masonry/ concrete	25 min. (one side)	20 mm Stone wool 40 kg/m <sup>3</sup>	E 240 – T – X – F – W 30 EI 60 – T – X – F – W 30
	15 min. (both sides)		EI 240 – V – X – F – W 30 EI 240 – T – X – F – W 30
	10 min. (one side)	60 mm Stone wool 33 kg/m <sup>3</sup>	E 240 – T – X – F – W 50 EI 60 – T – X – F – W 50 EI 120 – V – X – F – W 50
	25 min. (one side)	48 mm AES Fibre ≥ 128kg/m <sup>3</sup>	E 240 – T – X – F – W 30 EI 120 – T – X – F – W 30

#### A.4 Rigid floor constructions according to 1.2.1 with floor thickness of minimum 150 mm

##### A.4.1 Linear joint or gap seal, between floor slabs or between floor slab and wall with sealant to the top face of the floor only

**Joint Seal:** Kingspan K-Stop® Intumescent Mastic Plus to either side (or any position between) or both sides of the floor, joint widths up to 100 mm

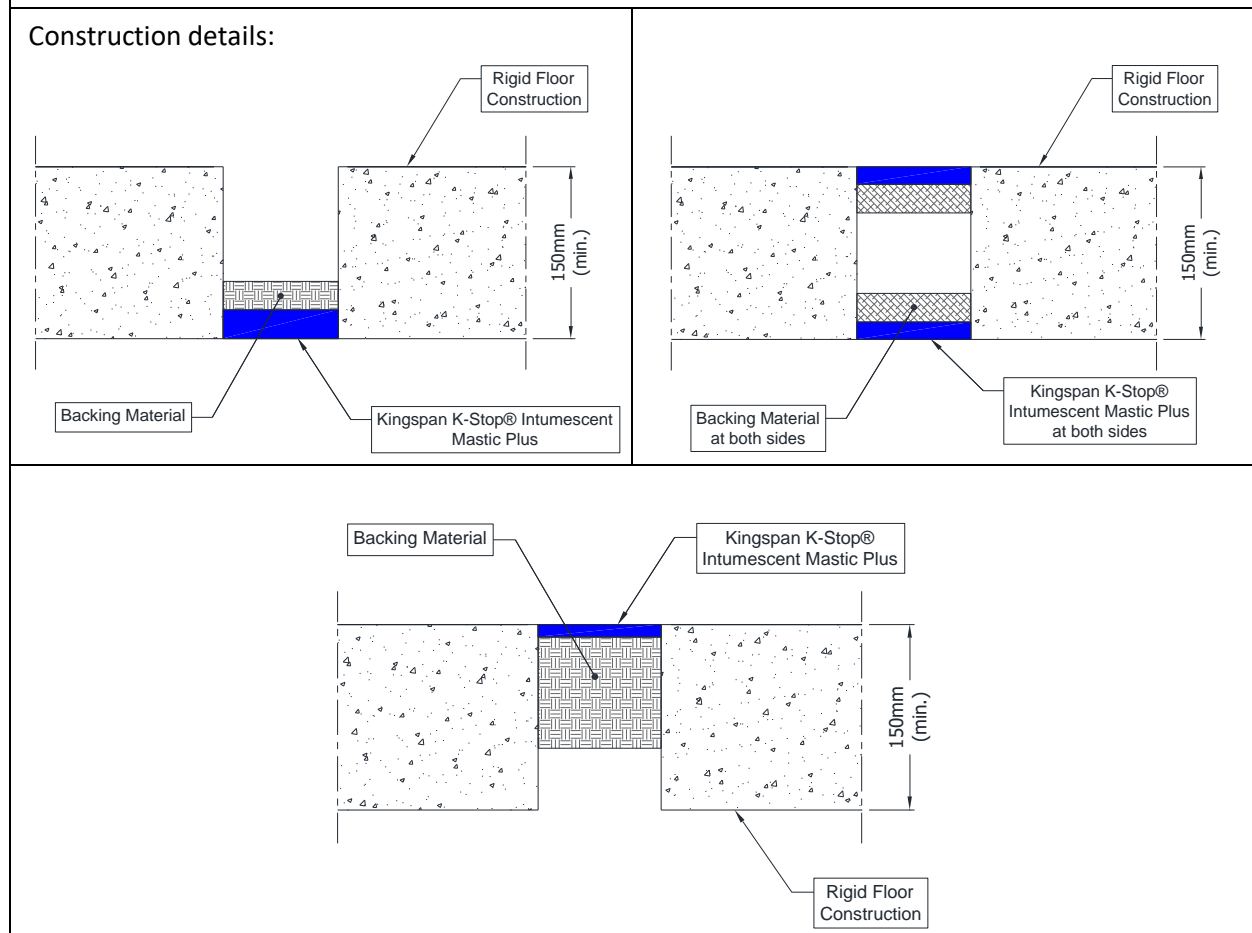

##### A.4.1.1

Substrate	Depth (mm)	Backing (minimum)	Classification
masonry/ concrete	25 min. (any position)	25 mm AES Fibre $\geq 128\text{kg/m}^3$	<b>E 120 – H – X – F – W 100</b> <b>EI 60 – H – X – F – W 100</b>
	25 min (top face)		<b>EI 180 – H – X – F – W 100</b>
	15 min. (both sides)	25 mm Stone wool $40\text{ kg/m}^3$	<b>EI 120 – H – X – F – W 100</b>
		25 mm Stone wool $140\text{ kg/m}^3$	<b>EI 180 – H – X – F – W 100</b>
	15 min. (both sides)	25 mm stone wool $35\text{ kg/m}^3$ insulation	<b>EI 240 – H – X – F – W 30</b>
10 min. (top face)	90 mm Stone wool $33\text{ kg/m}^3$	<b>EI 240 – H – X – F – W 100</b>	

#### A.4.2 Linear joint or gap seals, in or between rigid floors

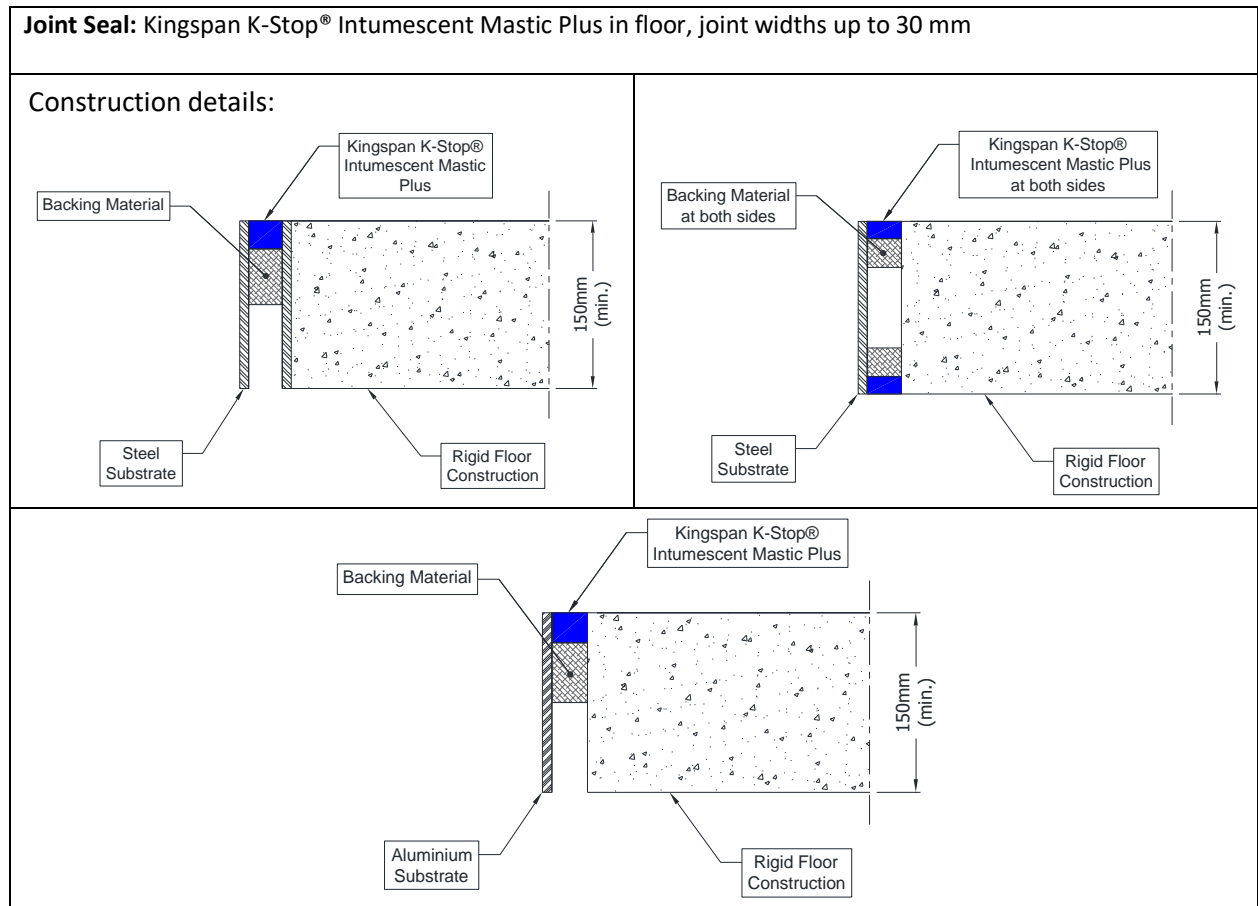

##### A.4.2.1

Substrate	Depth (mm)	Backing	Position	Classification
Steel/ steel or Steel/ concrete	25 min.	Stonewool, 50 mm deep min. 35 kg/m <sup>3</sup>	Top	E 240 – H – X – F – W 30 <sup>1</sup> EI 30 – H – X – F – W 30 <sup>2</sup>
	15 min.	Stonewool, 25 mm deep min. 35 kg/m <sup>3</sup>	Both	E 240 – H – X – F – W 30 <sup>3</sup> EI 45 – H – X – F – W 30 <sup>4</sup>
Aluminium / concrete	25 min.	Stonewool, 50 mm deep min. 35 kg/m <sup>3</sup>	Top	E 180 – H – X – F – W 30 <sup>5</sup> EI 20 – H – X – F – W 30 <sup>6</sup>

\*Additional and for information only.

The classifications provided in Table A.4.2.1 consider the insulation performance of all components within the firestopping system as per the requirements of EN 1366-4. This includes temperature evaluation of the steel substrate.

In relation to each of the above classifications, temperatures recorded on the seal (exclusive of the supporting construction) exceeded the maximum allowable after the following times (rounded down):

<sup>1</sup> 240, <sup>2</sup> 60, <sup>3</sup> 240, <sup>4</sup> 120, <sup>5</sup> 180, <sup>6</sup> 60